



Product catalog



Our **products** are used by over **4000** users
in more than **49** countries!



We operate in major industrial segments worldwide!

Products of the company are continuously improved so they can satisfy the demands of dynamically changing markets by offering the innovative and modern technological solutions. The diversity of chain application requires different technical parameters and properties of each product. Thus, FASING offers wide range of chains and accessories that are produced according to the specific customer requirements so one may receive the product adapted to the needs of end users. Under this approach, our motto is:

„There are no perfect chains that meet all the requirements,
but there are chains that are perfectly suited for specific conditions.“

The worldwide success of FASING lies above all in the highest quality and wide range of its products. Since 2003 FASING has operated on the basis of Integrated Quality and Environment Management System, PN EN ISO 9001 and PN EN ISO 14001 standards. The high quality and safety of the products are ensured by multiple, updated on a regular basis, attestations recognized in different global market, as well as, awards obtained in Poland and on an international scale.









Capital Group **FASING Plc.**

offers chains of diameter $\varnothing 9 - 60$ mm,
chain assemblies and accessories for:



and others

Table of contents

	Round link mining chains	2
	Flat link mining chains	8
	Chain assemblies	16
	Flight bars, clamps, locks	22
	Connecting links	27
	Wear resistant round link chains	33
	Lifting chains, chains for hoists	38
	Chains for marine and fishing industry, general purpose chains and accessories	43
	Basic concepts	51

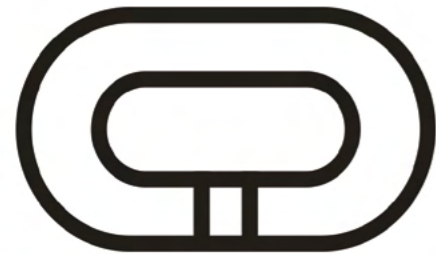

Round link mining chains

Over 100 years of experience allowed FASING to achieve the highest quality of round link mining chains. The detailed control that is performed at every stage of the production process, the use of highly optimized steel and the wide range of chain grades allows FASING to offer, pursuant to the company's motto, the chain that is perfectly suited for the specific conditions of its performance.

The quality of FASING mining chains is proved with recognition and customer satisfaction around the world.

Round link mining chains

acc. to DIN 22252, PN-G-46701 and FASING Technical Requirements

Application

Armored Face Conveyors, Beam Stage Loaders, road headers, coal plows, other equipment that requires this type of chain.

Product manufacturing

acc. to DIN 22252 or PN-G-46701 or GOST 25996 standard

 All anti-corrosive coatings decrease the chain mechanical properties; therefore, the application of any anticorrosion protection needs individual agreement with a customer when issuing purchase order.

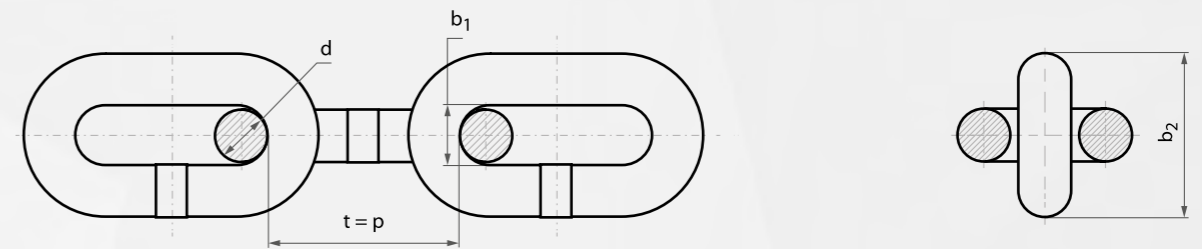

Dimensions

Chain size d × t (p)	Bar diameter d	Pitch t = p	b ₁ ** min.	b ₂ ** max.	~Weight [kg/m]
[mm]	[mm]	[mm]	[mm]	[mm]	
14×50	14 ± 0.4	50 ± 0.5	17	48	4.0
18×64	18 ± 0.5	64 ± 0.6	21	60	6.6
19×64.5	19 ± 0.6	64.5 ± 0.6	22	63	7.4
22×86	22 ± 0.7	86 ± 0.9	26	73	9.5
24×86	24 ± 0.7	86 ± 0.9	28	79	11.6
24×87.5	24 ± 0.7	87.5 ± 0.9	28	79	11.5
26×92	26 ± 0.8	92 ± 0.9	30	85	13.7
30×108	30 ± 0.9	108 ± 1.1	34	97	18.0
34×126	34 ± 1.0	126 ± 1.3	38	110	22.7
38×126	38 ± 1.1	126 ± 1.4	42	121	30.1
38×137*	38 ± 1.1	137 ± 1.4	42	121	29.0
42×137*	42 ± 1.1	137 ± 1.4	48	137	36.9
42×146	42 ± 1.1	146 ± 1.5	48	137	36.0

Other chain sizes e.g. 38×146, 42×152, 48×152 are to be manufactured according to individual agreement with a customer.

* chains for coal plows

** other standards may include the following designations: b₁ = a; b₂ = b

Link chains of increased properties

Grades PW-9, C-SUPER, D-3, D-3 EXTRA, E-FASING

Chains of increased grade properties: PW-9 (>900 MPa), C-SUPER (>900 MPa), D-3 (>1000 MPa), D-3 EXTRA (>1050 MPa), E-FASING (>1100 MPa) are characterized by much higher performance parameters in comparison to chains mentioned in PN and DIN standards. The increased durability and operation strength of the chains is a result of introducing the highest quality steel to the production process. The applied steel is customized, highly optimized – conforming to DIN 17115, PN-92/H-93028 standards, with alloy micro-additions acc. to FASING Technical Specifications. The WO steel and special, multiple heat treatment guarantee to achieve higher, more favourable actual technical and performance parameters in chains. This technology provides an optimal, repetitive hardness distribution in every link, moreover, in the case of PW-9, D-3, D-3 EXTRA, E-FASING grades it allows obtaining diverse hardness in one single link, i.e. hard crowns and plasticized legs of lower hardness. It is not recommended to use chains of increased properties, particularly the chains of the highest grade i.e. D-3 EXTRA and E-FASING in harsh, aggressive environment because of the risk posed by pitting corrosion and friction martensite that lead to operation failure.



In such cases, we suggest individual chain selection to specific performance conditions. Depending on the longwall degree of aggressiveness, we advise using various types of protection applied onto the chain surface:

- preservation with special anti-corrosive lubricant FAS-KBP 50/00/22,
- preservation with special anti-corrosive oil,
- hot dip galvanizing FAS-Zn-O,
- metallization (inlet protection) FAS-Zn-M.

On the basis of DIN 22252 standard, mechanical properties of round link chains apply to dry, natural black state, which occurs after technological production process. Pursuant to the standard, the chain strength parameters which include protective coatings are decreased ca. 10-20%. This percentage change must be considered when selecting the chain or making calculations. This phenomenon is known as the Rebinder effect.

Comparison of chain strength parameters depending on chain grade: C, PW-9, D-3, D-3 EXTRA, E-FASING acc. to FASING Technical Requirements

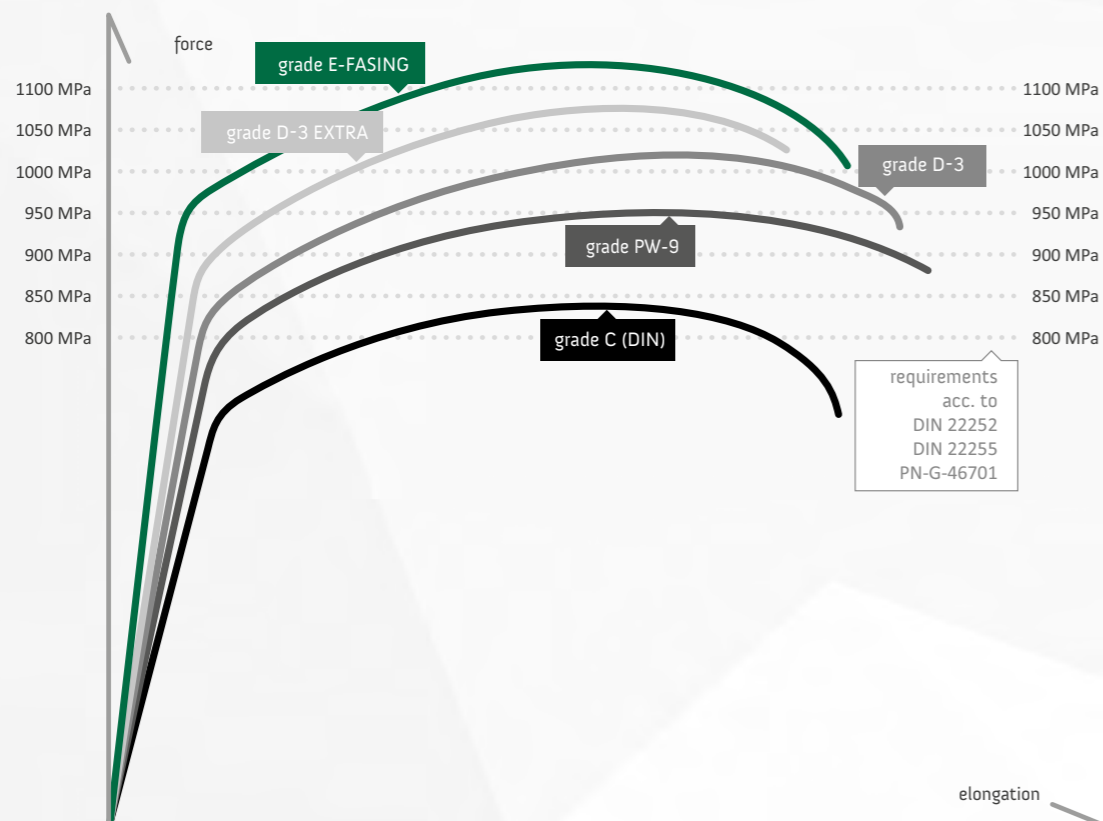

Mechanical properties

Chain size d × t (p)	Chain grade	Test force [kN]	Breaking force min. [kN]	Unit elongation at test force max. [%]	Unit elongation at breaking force min. [%]	Deflection f min. [mm]	Fatigue resistance min. [cycles]
14×50	B	150	190	1.4	14	14	50 000
	C; DIN 22252	200	250	1.6	14	14	70 000
	C-PLUS	185	262	1.6	14	14	70 000
	C-SUPER	200	280	1.6	18	14	70 000
	C-SUPER/380N	200	280	1.6	18	14	110 000
	PW-9	185	280	1.4	17	14	90 000
	PW-9/400N	185	280	1.4	17	14	110 000
	D	250	310	1.9	16	14	90 000
18×64	D-3	220	310	1.6	16	14	120 000
	B	260	320	1.4	14	18	50 000
	C; DIN 22252	330	410	1.6	14	18	70 000
	C-PLUS	305	425	1.6	14	18	70 000
	C-SUPER	330	460	1.6	18	18	70 000
	C-SUPER/380N	330	460	1.6	18	18	110 000
	PW-9	305	460	1.4	17	18	90 000
	PW-9/400N	305	460	1.4	17	18	110 000
	D	410	510	1.9	16	18	90 000
	D-3	360	510	1.6	16	18	120 000
18×64 19×64 19×64.5	D-3 EXTRA	360	535	1.6	14	18	90 000
	E-FASING	360	560	1.6	14	18	90 000
	B	290	360	1.4	14	19	50 000
	C; DIN 22252	360	450	1.6	14	19	70 000
	C-PLUS	340	480	1.6	14	19	70 000
	C-SUPER	360	510	1.6	18	19	70 000
	C-SUPER/380N	360	510	1.6	18	19	110 000
	PW-9	340	510	1.4	17	19	90 000
	PW-9/400N	340	510	1.4	17	19	110 000
	D	450	565	1.9	16	19	90 000
22×86	D-3	400	565	1.6	16	19	120 000
	D-3 EXTRA	400	595	1.6	14	19	90 000
	E-FASING	400	625	1.6	14	19	90 000
	B	380	490	1.4	14	22	50 000
	C; DIN 22252	490	610	1.6	14	22	70 000
	C-PLUS	456	645	1.6	14	22	70 000
	C-SUPER	490	680	1.6	18	22	70 000
	C-SUPER/380N	490	680	1.6	18	22	110 000
	PW-9	456	680	1.4	17	22	90 000
	PW-9/400N	456	680	1.4	17	22	110 000
22×86	D	610	760	1.9	16	22	90 000
	D-3	530	760	1.6	16	22	120 000
	D-3 EXTRA	530	800	1.6	14	22	90 000
	E-FASING	530	840	1.6	14	22	90 000

Mechanical properties

Chain size d × t (p)	Chain grade	Test force	Breaking force min.	Unit elongation at test force max.	Unit elongation at breaking force min.	Deflection f min.	Fatigue resistance min.
[mm]		[kN]	[kN]	[%]	[%]	[mm]	[cycles]
24×86 24×87.5	B	460	570	1.4	14	24	50 000
	C; DIN 22252	580	720	1.6	14	24	70 000
	C-PLUS	543	770	1.6	14	24	70 000
	C-SUPER	580	815	1.6	18	24	70 000
	C-SUPER/380N	580	815	1.6	18	24	110 000
	PW-9	543	815	1.4	17	24	90 000
	PW-9/400N	543	815	1.4	17	24	110 000
	D	720	900	1.9	16	24	90 000
	D-3	630	900	1.6	16	24	120 000
	D-3 EXTRA	630	950	1.6	14	24	90 000
E-FASING	630	995	1.6	14	24	90 000	
26×92	B	540	670	1.4	14	26	50 000
	C; DIN 22252	640	850	1.6	14	26	70 000
	C-PLUS	637	905	1.6	14	26	70 000
	C-SUPER	700	960	1.6	18	26	70 000
	C-SUPER/380N	700	960	1.6	18	30	110 000
	PW-9	640	960	1.4	17	26	90 000
	PW-9/400N	640	960	1.4	17	30	110 000
	D	790	1 060	1.9	16	26	90 000
	D-3	740	1 060	1.6	16	33	120 000
	D-3 EXTRA	740	1 115	1.6	14	26	90 000
E-FASING	740	1 170	1.6	14	26	90 000	
30×108	C; DIN 22252	850	1 130	1.6	14	30	70 000
	C-PLUS	848	1 202	1.6	14	30	70 000
	C-SUPER	950	1 280	1.6	18	30	70 000
	C-SUPER/380N	950	1 280	1.6	18	34	110 000
	PW-9	850	1 270	1.4	17	30	90 000
	PW-9/400N	850	1 270	1.4	17	34	110 000
	D	1 050	1 400	1.9	16	30	90 000
	D-3	990	1 400	1.6	16	38	120 000
	D-3 EXTRA	990	1 490	1.6	14	30	90 000
	E-FASING	990	1 555	1.6	14	30	90 000
34×126	C; DIN 22252	1 080	1 450	1.6	14	34	70 000
	C-PLUS	1 090	1 543	1.6	14	34	70 000
	C-SUPER	1 200	1 650	1.6	18	34	70 000
	C-SUPER/380N	1 200	1 650	1.6	18	38	110 000
	PW-9	1 080	1 640	1.4	17	34	90 000
	PW-9/400N	1 080	1 640	1.4	17	38	110 000
	D	1 350	1 800	1.9	16	34	90 000
	D-3	1 270	1 800	1.6	16	43	120 000
	D-3 EXTRA	1 270	1 910	1.6	14	34	90 000
	E-FASING	1 270	2 000	1.6	14	34	90 000

Mechanical properties

Chain size d × t (p)	Chain grade	Test force	Breaking force min.	Unit elongation at test force max.	Unit elongation at breaking force min.	Deflection f min.	Fatigue resistance min.
[mm]		[kN]	[kN]	[%]	[%]	[mm]	[cycles]
38×126 38×137	C; DIN 22252	1 360	1 810	1.6	14	38	70 000
	C-PLUS	1 360	1 930	1.6	14	38	70 000
	C-SUPER	1 500	2 040	1.6	18	38	70 000
	C-SUPER/380N	1 500	2 040	1.6	18	42	110 000
	PW-9	1 360	2 000	1.4	17	38	90 000
	PW-9/400N	1 360	2 040	1.4	17	42	110 000
	PW-9/400N-S*	1 360	1 960	1.4	17	42	110 000
	D	1 700	2 270	1.9	16	38	90 000
	D-3	1 590	2 270	1.6	16	48	120 000
	D-3 EXTRA	1 590	2 380	1.6	14	38	90 000
E-FASING	1 590	2 495	1.6	14	38	90 000	
42×137 42×146	C; DIN 22252	1 660	2 220	1.6	14	42	70 000
	C-PLUS	1 660	2 355	1.6	14	42	70 000
	C-SUPER	1 800	2 500	1.6	18	42	70 000
	C-SUPER/380N	1 800	2 500	1.6	18	48	110 000
	PW-9	1 660	2 500	1.4	17	42	90 000
	PW-9/400N	1 660	2 500	1.4	17	48	110 000
	PW-9/400N-S*	1 660	2 400	1.4	17	48	110 000
	D	2 070	2 770	1.9	16	42	90 000
	D-3	1 940	2 770	1.6	16	53	120 000
	D-3 EXTRA	1 940	2 910	1.6	14	42	90 000
E-FASING	1 940	3 050	1.6	14	42	90 000	

* chains for coal plows

Parameters

Fatigue resistance T [cycles] and impact force KV [J] according to DIN 22252 standard and FASING Technical Requirements; in other cases to be agreed with FASING.



Flat link mining chains
acc. to DIN 22255
and FASING Technical Requirements

Flat link mining chains may replace currently used round link chains of the same diameter, without the need of changing other assembly components. Alternatively, flat link chains enable to use lower profiles in conveyors because the vertical links, produced according to DIN 22255 standard, are of the same height as round links, which are made acc. to DIN 22252 standard. The latter are smaller by an order of diameter value, e.g. flat link chain 34x126 is of the height $b_4 = \text{max. } 94$ which corresponds to round link chain 30x108 $b_2 = \text{max. } 97$.

The chain's vertical links are forged. FASING has developed Technical Requirements for the chain grades that have different mechanical properties in comparison to the ones provided in DIN 22255 standard. Upon customer's request, flat link chains may be manufactured according to the Chinese standard MT/T 929.

Application

Armored Face Conveyors, Beam Stage Loaders, road headers.

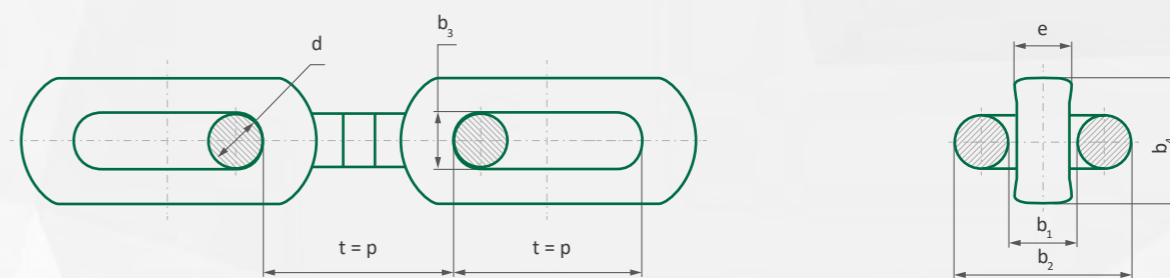

Dimensions

Chain size $d \times t(p)$ [mm]	Bar diameter d [mm]	Pitch $t = p$ [mm]	Round horizontal link		Flat vertical link		e max. [mm]	~ Weight [kg/m]
			b_1 min. [mm]	b_2 max. [mm]	b_3 min. [mm]	b_4 max. [mm]		
26x92	26 ± 0.8	92 ± 0.9	30.1	87	30	75	30.0	13.7
30x108	30 ± 0.9	108 ± 1.1	34.1	99	34	87	34.0	18.0
34x126	34 ± 1.0	126 ± 1.3	38.1	111	38	99	38.0	22.7
38x126	38 ± 1.1	126 ± 1.3	42.1	123	42	111	42.0	30.1
38x137	38 ± 1.1	137 ± 1.4	42.1	123	42	111	42.0	29.0
38x146	38 ± 1.1	146 ± 1.5	42.1	123	42	111	42.0	27.6
42x137	42 ± 1.1	137 ± 1.4	48.6	139	46	115	48.5	37.0
42x146	42 ± 1.1	146 ± 1.5	48.6	139	46	115	48.5	36.0
48x152	48 ± 1.4	152 ± 1.5	a^*	a^*	54	127	56.0	47.0

* dimension to be consulted with the producer

Flat link mining chains



FASING produces four types of flat link chains:

- acc. to DIN 22255 standard
- Master Profile double flat (acc. to DIN 22255 and FASING Technical Requirements)
- Master Profile triple flat (acc. to DIN 22255 and FASING Technical Requirements)
- Solid Profile (acc. to DIN 22255 and FASING Technical Requirements)

Vertical links in flat chains are of smaller height in comparison to horizontal links. At the same time, the chain does not lose its mechanical properties in the case of each size and grade.

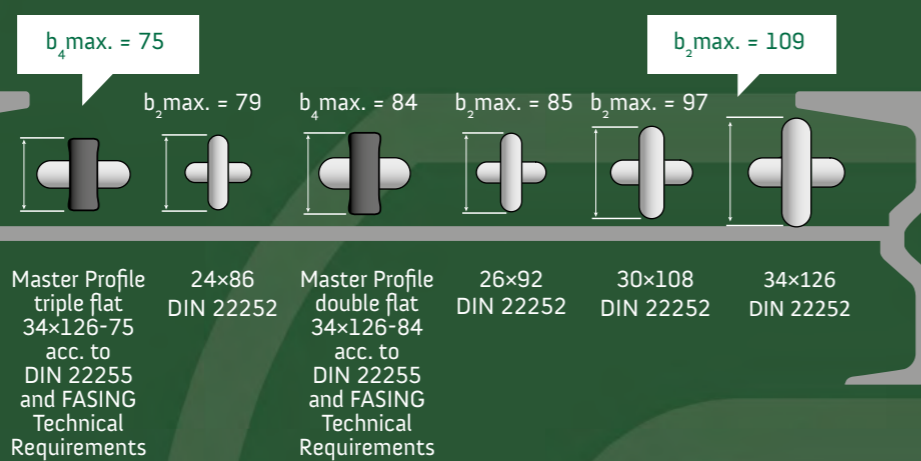

Double and triple flat chains on the example of 34x126-84, 34x126-75

Double flat mining chains Master Profile

acc. to DIN 22255
and FASING Technical Requirements

Master Profile double flat chains have all the advantages of flat chains produced acc. to DIN 22255. Moreover, they are characterized by even smaller vertical link height, which allows to increase the distance between conveyor metal sliding sheet and the pans. For this reason, the risk of friction martensite and the following performance failure is minimized. At the same time, the flight bar durability is extended as its permitted wear degree of higher value does not affect chain vertical links. The vertical links in a double flat chain are of the same height as round links made acc. to DIN 22252 standard, which are twice as smaller in diameter as for example double flat link chain 42x146-109 of height $b_4 = \max. 109$ which corresponds to round link height 34x126, $b_2 = \max. 110$.

Chain performance durability has been also improved thanks to special geometry achieved by computer simulations, which allowed for strengthening the critical areas and increase the size of a flat surface which rubs against the metal sliding sheet. It reduces the unit pressure in comparison to round link chains. Double flat link chains cooperate with the standard sprockets acc. to DIN 22256, flight bars acc. to DIN 22257 and locks acc. to DIN 22253 / PN-G-46696 - the chains may replace currently used round or flat link chains acc. to DIN 22255.



For the grades that differ in mechanical properties and sizes in comparison to the ones provided in DIN 22255 standard, FASING has developed its own Technical Requirements.

FASING has introduced double flat link chains 22x86-61 and 24x86-64 into production and sales. They are manufactured on the basis of DIN 22255 standard and FASING Technical Requirements.

The products have been awarded with:

- The Innovative Product – Katowice 2015, Katowice 2017, Katowice 2019
- Mining Success of the Year 2015 in the category "INNOVATION", Katowice 2015
- The highest quality product for Double flat mining link chain FASING 22x86-61 and 24x86-64, Katowice 2019

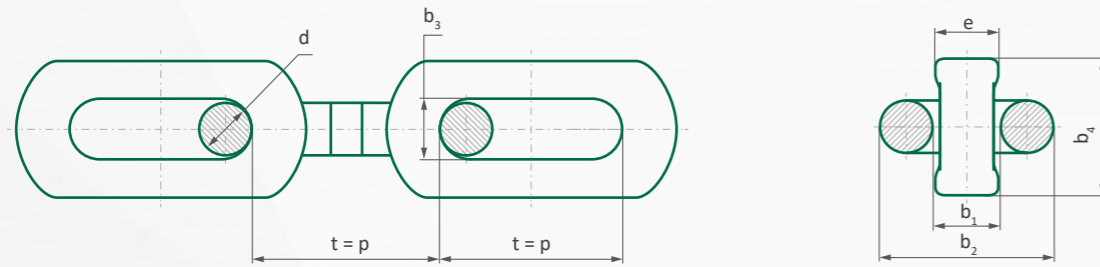

Double flat chains on the example of 42x146-109, 48x152-115 and 48x152-121

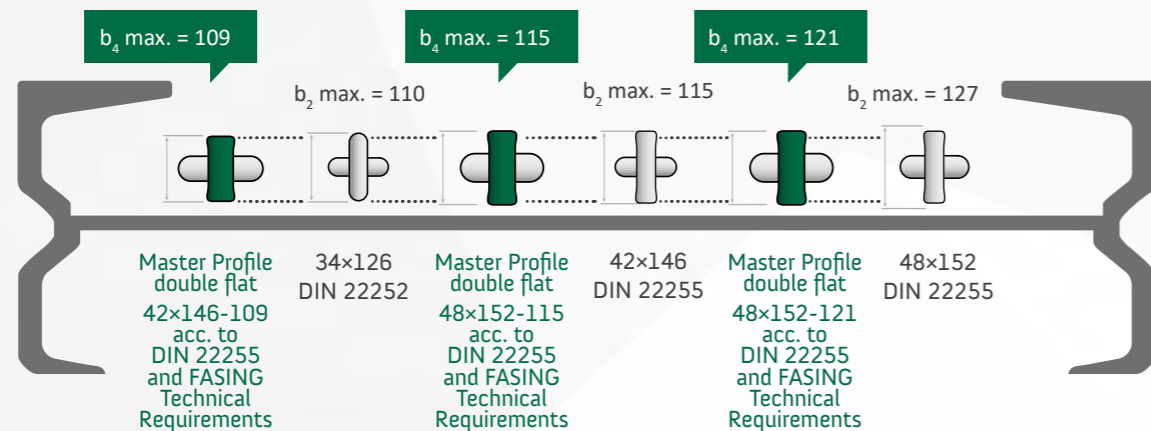

Dimensions

Chain size $d \times t (p) - b_4$	Bar diameter d	Pitch $t = p$	Round horizontal link		Flat vertical link		e max.	~Weight [kg/m]
			$b_1 \min.$ [mm]	$b_2 \max.$ [mm]	$b_3 \min.$ [mm]	$b_4 \max.$ [mm]		
22x86-61	22 ± 0.7	86 ± 0.8	27.0	74.0	26	61	26.0	9.9
24x86-64	24 ± 0.7	86 ± 0.8	30.8	81.3	28	64	28.0	12.2
26x92-70	26 ± 0.8	92 ± 0.9	30.1	87.0	30	70	30.0	13.7
30x108-80	30 ± 0.9	108 ± 1.1	34.1	99.0	34	80	34.0	17.7
34x126-84	34 ± 1.0	126 ± 1.3	39.0	111.0	38	84	38.0	22.7
34x126-94	34 ± 1.0	126 ± 1.3	38.1	111.0	38	94	38.0	22.7
38x126-101	38 ± 1.1	126 ± 1.3	42.1	123.0	42	101	42.0	30.1
38x137-101	38 ± 1.1	137 ± 1.4	42.1	123.0	42	101	42.0	29.0
42x146-109	42 ± 1.1	146 ± 1.5	48.6	139.0	46	109	48.5	36.0
48x152-115	48 ± 1.4	152 ± 1.5	64.0	163.0	52	115	58.0	47.0
48x152-121	48 ± 1.4	152 ± 1.5	62.0	163.0	52	121	53.0	47.0
48x144/160	48 ± 1.4	160 ± 1.6 / 144 ± 1.5	62.0	163.0	52	115	57.0	48.0
52x170-128	52 ± 1.9	170 ± 1.7	65.0	177.0	54	128	64.0	53.3
56x187-132	56 ± 1.9	187 ± 1.9	70.0	189.0	60	132	65.0	62.0
60x181/197	60 ± 1.9	197 ± 2.0 / 181 ± 1.8	72.0	198.0	63	136	70.0	71.0

Mechanical properties

Chain size $d \times p$	Chain grade	Measuring force	Test force	Breaking force min.	Unit elongation at test force max.	Unit elongation at breaking force min.	Fatigue resistance min.
22x86-61	C; DIN 22255	19	456	608	1.6	14	70 000
	C-PLUS		456	646			70 000
	C-SUPER		490	680			70 000
	PW-9		456	680	1.4	11	90 000
	D		530	760			90 000
	D-3		530	760			120 000
	D-3 EXTRA		530	800			90 000
	E-FASING	530	840	90 000			
24x86-64	C; DIN 22255	23	543	724	1.6	14	70 000
	C-PLUS		543	769			70 000
	C-SUPER		580	815			70 000
	PW-9		543	815	1.4	11	90 000
	D		630	900			90 000
	D-3		630	900			120 000
	D-3 EXTRA		630	950			90 000
	E-FASING	630	995	90 000			
26x92-70	C; DIN 22255	26	637	850	1.6	14	70 000
	C-PLUS		637	903			70 000
	C-SUPER		700	970			70 000
	PW-9		640	960	1.4	11	90 000
	D		740	1060			90 000
	D-3		740	1060			120 000
	D-3 EXTRA		740	1115			90 000
	E-FASING	740	1170	90 000			

Mechanical properties

Chain size d × p	Chain grade	Measuring force	Test force	Breaking force min.	Unit elongation		Fatigue resistance
					at test force max. [%]	at breaking force min. [%]	
[mm]		[kN]	[kN]	[kN]			min. [cycles]
30×108 30×108-80	C; DIN 22255	35	848	1 130	1.6	11	70 000
	C-PLUS		848	1 202		70 000	
	C-SUPER		950	1 280		70 000	
	PW-9		850	1 270	1.4	11	90 000
	D		990	1 400			90 000
	D-3		990	1 400			120 000
	D-3 EXTRA		990	1 490			90 000
	E-FASING		990	1 555			90 000
34×126 34×126-94	C; DIN 22255	45	1 090	1 450	1.6	11	70 000
	C-PLUS		1 090	1 543		70 000	
	C-SUPER		1 200	1 650		70 000	
	PW-9		1 090	1 640	1.4	11	90 000
	D		1 270	1 800			90 000
	D-3		1 270	1 800			120 000
	D-3 EXTRA		1 270	1 910			90 000
	E-FASING		1 270	2 000			90 000
34×126-84	C; DIN 22255	45	1 090	1 450	1.6	11	70 000
	C-PLUS		1 090	1 540			70 000
	C-SUPER		1 200	1 640	1.2		70 000
	PW-9		1 090	1 640			90 000
38×126 38×126-101 38×137 38×137-101 38×146	C; DIN 22255	57	1 360	1 820	1.6	11	70 000
	C-PLUS		1 360	1 930		70 000	
	C-SUPER		1 500	2 040		70 000	
	PW-9		1 360	2 040	1.4	11	90 000
	D		1 590	2 270			90 000
	D-3		1 590	2 270			120 000
	D-3 EXTRA		1 590	2 380			90 000
	E-FASING		1 590	2 495			90 000
42×146 42×146-109	C; DIN 22255	69	1 660	2 220	1.6	11	70 000
	C-PLUS		1 660	2 355		70 000	
	C-SUPER		1 800	2 500		70 000	
	PW-9		1 660	2 500	1.4	11	90 000
	D		1 940	2 770			90 000
	D-3		1 940	2 770			120 000
	D-3 EXTRA		1 940	2 910			90 000
	E-FASING		1 940	3 050			90 000

Mechanical properties

Chain size d × p	Chain grade	Measuring force	Test force	Breaking force min.	Unit elongation		Fatigue resistance
					at test force max. [%]	at breaking force min. [%]	
[mm]		[kN]	[kN]	[kN]			min. [cycles]
48×152 48×152-115 48×152-121 48×144/160-115	C; DIN 22255	90	1 900	2 900	1.6	11	70 000
	C-PLUS		1 900	3 075		70 000	
	C-SUPER		2 350	3 255		70 000	
	PW-9		2 170	3 255	1.4	11	90 000
	D		2 530	3 600			90 000
	D-3		2 530	3 600			120 000
	D-3 EXTRA		2 530	3 800			90 000
	E-FASING		2 530	3 980			90 000
52×170-128	C; DIN 22255	106	2 210	3 400	1.2	11	70 000
	C-PLUS		2 210	3 600			70 000
	C-SUPER		2 450	3 820			70 000
	PW-9		2 210	3 820	1.6		90 000
	D		2 640	4 250			90 000
	D-3		2 640	4 250			120 000
56×187-132	C; DIN 22255	123	2 610	3 960	1.2	11	70 000
	C-PLUS		2 610	4 190			70 000
	C-SUPER		2 880	4 400	1.6		70 000
	PW-9		2 610	4 400			90 000
	D		3 000	4 900			90 000
	D-3		3 000	4 900			120 000
60×181/197-136	C; DIN 22255	141	3 000	4 520	1.2	11	70 000
	C-PLUS		3 000	4 800			70 000
	C-SUPER		3 400	5 100	1.6		70 000
	PW-9		3 000	5 100			90 000
	D		3 500	5 650			90 000
	D-3		3 500	5 650			120 000

Triple flat mining chains

Master Profile

acc. to DIN 22255
and FASING Technical Requirements

Master Profile triple flat mining chains are innovative products in which the height of vertical links has been lowered even further in comparison to the height of double flat chains. The chains are of special design which allows them to be a part of the most efficient haulage systems, having significantly greater strength and durability in comparison to round link chains made acc. to DIN 22252 or flat link chains acc. to DIN 22255 of the same height. Vertical links in triple flat mining chains are as high as round links produced acc. to DIN 22252, which are three sizes smaller in diameter, e.g. triple flat link chain 34×126-75 is of height $b_4 = \text{max. } 75$ that corresponds to the height of round link chain 24×86, $b_2 = \text{max. } 79$.



Master Profile triple flat chains are extra strengthened with a central stud, which prevents the chain against any entanglement.

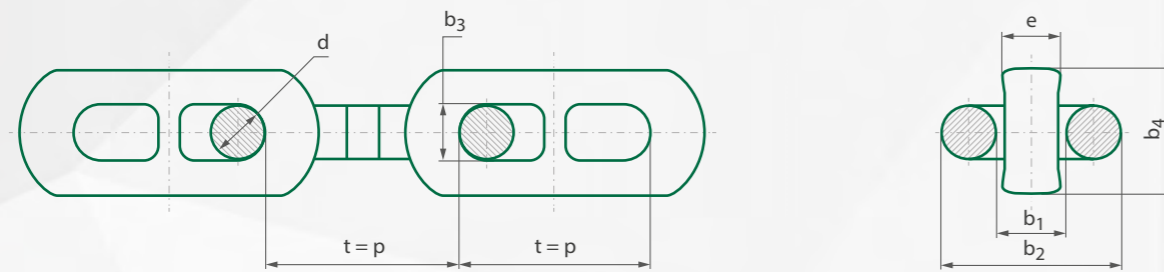

Dimensions

Chain size $d \times p(t) - b_4$	Bar diameter d	Pitch t = p	Horizontal round link		Vertical flat link		e max.	~Weight [kg/m]
			b_1 min. [mm]	b_2 max. [mm]	b_3 min. [mm]	b_4 max. [mm]		
[mm]	[mm]	[mm]	[mm]	[mm]	[mm]	[mm]	[mm]	[kg/m]
34×126-75	34 ± 1.0	126 ± 1.3	39	111	36	75	38	21.5
42×146-100	42 ± 1.1	146 ± 1.5	60	147	44	100	56	39.1

Mechanical properties

Chain size $d \times p(t) - b_4$	Chain grade	Test force	Breaking force min.	Unit elongation at test force max. [%]	Unit elongation at breaking force min. [%]
[mm]		[kN]	[kN]		
34×126-75	C; DIN 22255	1 090	1 450	1.6	11
42×146-100	C; DIN 22255	1 660	2 220	1.6	11
	C-PLUS	1 660	2 360	1.6	11

Solid Profile

acc. to DIN 22255
and FASING Technical Requirements



Solid Profile chains are characterized by the special vertical link geometry, which enables to reduce the chain height even more than in the case of the double-flat chains. This makes it possible to reduce the height of the pan profile and to increase the loading capacity of the conveyor. The wide vertical links also have the largest contact surface with the pan sliding sheet and the contact surface between the horizontal and vertical chain links, which allows to significantly reduce the chain wear during operation, to decrease its elongation during operation and at the same time to minimize as much as possible the risk of its damage due

to friction martensite. The chain geometry protects the links against jamming and, combined with a special heat treatment, the chain mechanical parameters exceed by more than 65% the requirements of the DIN 22255 standard. All the above-mentioned features make Solid Profile chains the first choice for the highest drive powers application and operation on the mining faces. FASING produces Solid Profile chains in a range of sizes with horizontal link diameter 38-60 mm.

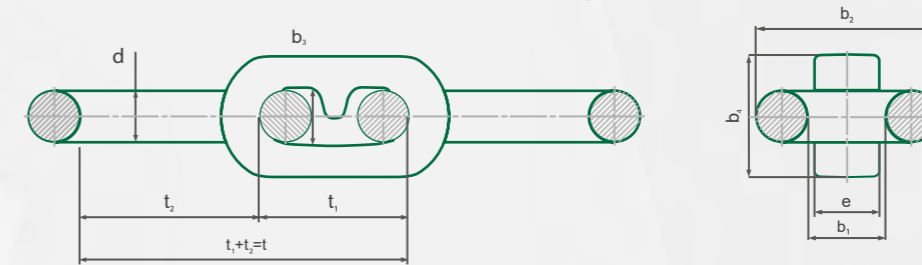

Dimensions

Chain size $d \times t_1/t_2$	Bar diameter d	Pitch $t_1 + t_2 = t$	Horizontal round link		Vertical flat link		e max.	~Weight [kg/m]
			b_1 min. [mm]	b_2 max. [mm]	b_3 min. [mm]	b_4 max. [mm]		
[mm]	[mm]	[mm]	[mm]	[mm]	[mm]	[mm]	[mm]	[kg/m]
38×126/148	38 ± 1.1	126 + 148 = 274 ± 1.5	62	143	42	88	54	30.0
42×128/164	42 ± 1.1	128 + 164 = 292 ± 1.6	71	159	46	99	60	37.0
50×146/174	50 ± 1.5	146 + 174 = 320 ± 1.7	76	178	52	116	64	49.0
56×168/204	56 ± 1.6	168 + 204 = 372 ± 2.0	88	206	60	130	75	65.0

Mechanical properties

Chain size $d \times t_1/t_2$	Chain grade	Test force	Breaking force min.	Unit elongation at test force max. [%]	Unit elongation at breaking force min. [%]	Fatigue resistance min. [cycles]
[mm]		[kN]	[kN]			
38×126/148	C; DIN 22255	1 360	1 820	1.6	11	70 000
	C-PLUS		1 930			70 000
	SP		1 950			70 000
	PW-9		2 040			90 000
42×128/164	C; DIN 22255	1 660	2 220	1.6	11	70 000
	C-PLUS		2 360			70 000
	SP		2 380			70 000
	PW-9		2 500			90 000
50×146/174	C; DIN 22255	2 060	3 140	1.6	11	70 000
	C-PLUS		3 340			70 000
	SP		3 400			70 000
	PW-9		3 530			90 000
56×168/204	C; DIN 22255	2 600	3 940	1.6	11	70 000
	C-PLUS		4 190			70 000
	SP		4 240			70 000
	PW-9		4 430			90 000

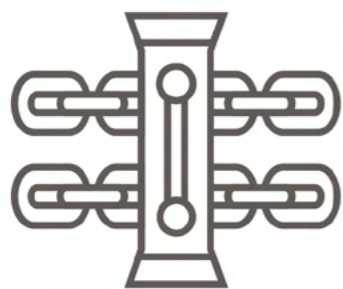

Chain assemblies

Chain assemblies with one, two, three and more chain strands of outboard and inboard chain guidance, including flight bars, clamps, locks, have been made according to the relevant technical documentation and individual construction designs. The assemblies are used in mining conveyors, heating industry, agriculture, power industry, metallurgy and other branches of the economy. According to the technical design and customer request, chain assemblies may be fitted with a standard chain, a chain of increased strength parameters, wear-resistant or case hardened chain. The mechanical properties of the chains applied in the assemblies are presented in the relevant chapters of this catalog.

Twin inboard chain assemblies

The applied chain

- 18×64, 19×64, 19×64.5 grade C or PW-9 for assembly length from 80 to 200 m; grade PW-9 for assembly length from 40 to 200 m; grade FAS-UT, FAS-US or FAS-US EXTRA for short conveyors of length up to 40 m.

Product manufacturing

Twin inboard chain assemblies to chain conveyors for preparatory works (PRP-150) are primarily made in segments of 321 link length = 20.544 mm, by applying the following chains of specially selected parameters, lengths and tolerances: 18×64, 19×64, 19×64.5 acc. to DIN 22252, PN-G-46701 and wear resistant, forged flight bars and clamps which are assembled with self-locking nuts or according to other individual solutions.

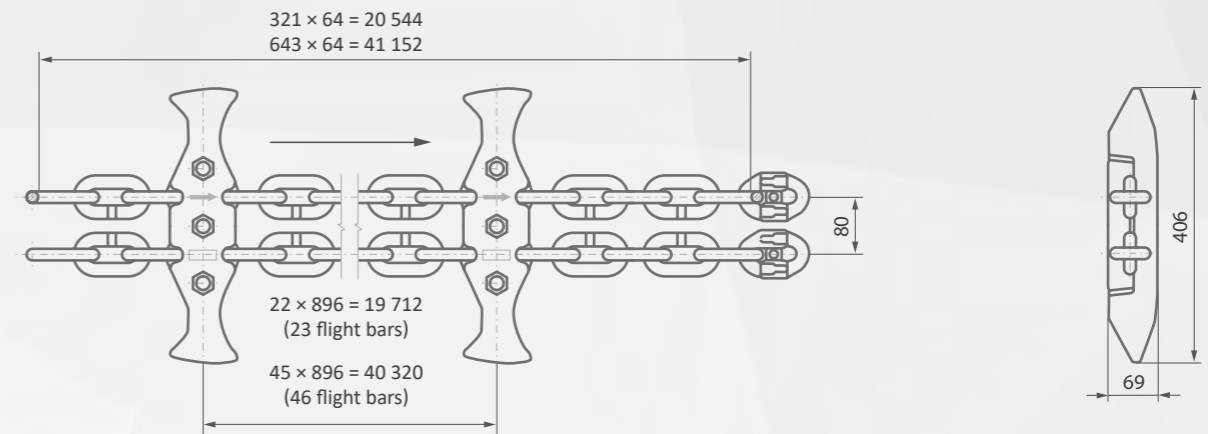

Twin inboard chain assemblies

to AM-50 road header

The applied chain

- 18×64, 19×64, 19×64.5 grade FAS-UT, FAS-US and FAS-US EXTRA

Product manufacturing

Twin inboard chain assemblies for AFCs in AM-50 road headers are primarily made in segments of 177 link length = 11.328 mm, by applying special hardened chains 18×64 grades FAS-UT, FAS-US, FAS-US EXTRA of higher wear resistance and properly selected lengths and tolerances. Chain assemblies are fitted with special, wear resistant, forged flight bars of strengthened, new construction, optimally matched to a profile of the pan E-180; they are assembled to forged clamps with high quality bolts and self-locking nuts.

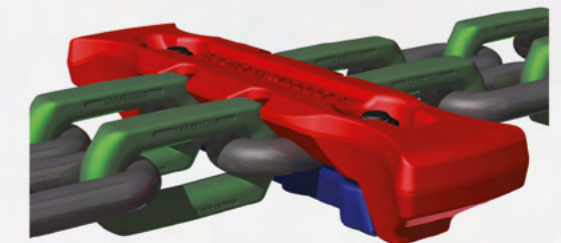

The chains are made of steel according to the requirements of DIN 17115 German standard and FASING specifications.

At the request of the customer, there is a possibility to apply double flat link chain 22×86-61 acc. to DIN 22255 and FASING Technical Requirements.

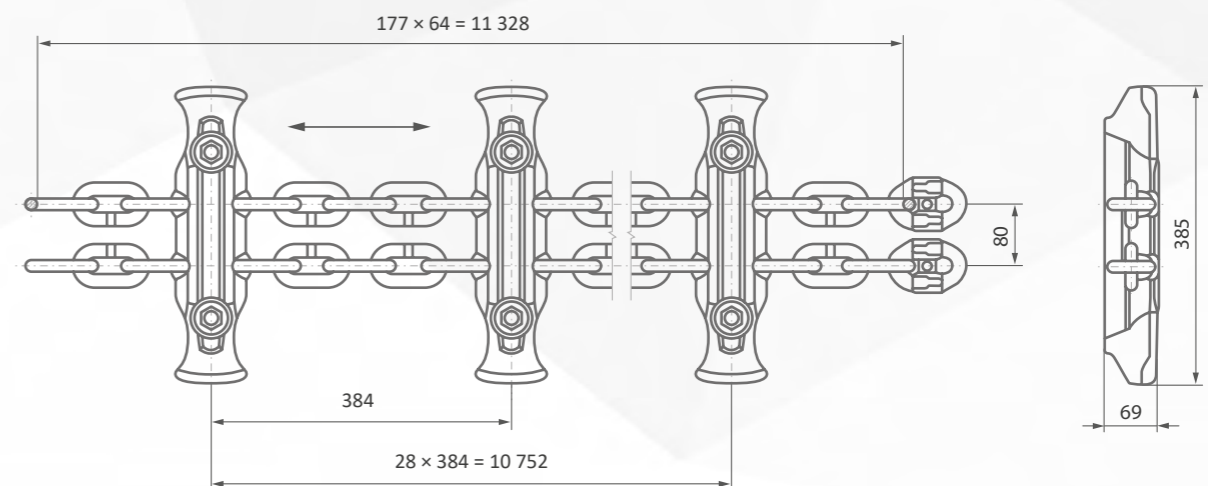

Twin outboard chain assemblies

to chain conveyors installed in AM-65, AM-75, AM-85, AM-105 road headers

The applied chain

- 18×64, 19×64, 19×64.5 grade FAS-UT, FAS-US or FAS-US EXTRA with non-lock and lock-type flight bars

Product manufacturing

The complete twin outboard chain assemblies to AM-75 road headers are manufactured in segments of 95 link length = 6127.5 mm by applying exclusively selected chains 19×64.5 acc. to DIN 22252 German standard and wear-resistant, assembled flight bars. At the request of the customer, the length of paired chain strands may be individually agreed upon.

Non-lock chain assembly

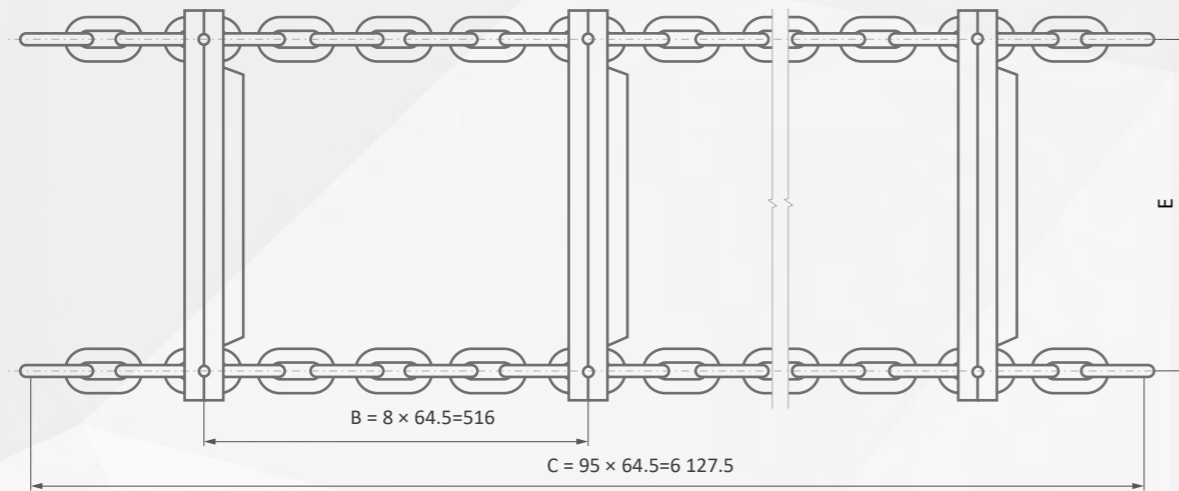

Lock type chain assembly

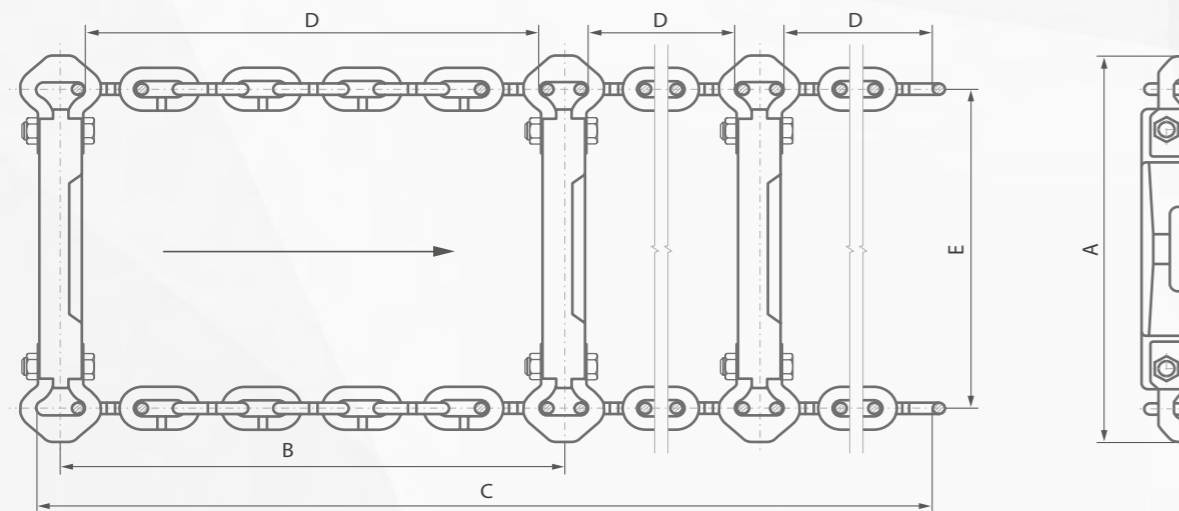

	Number of links	18/19×64	19×64,5		AM-65	AM-75	AM-85	AM-105
B [mm]	9	640	645	E [mm]	400	500	600	700
	15	1024	1032					
D [mm]	9	576 (9×64)	580.5 (9×64.5)	A [mm]	490	590	690	790
	15	960 (15×64)	967.5 (15×64.5)					
C [mm]	9	1920 (3×640)	1935 (3×645)					
	15	3072 (3×1024)	3096 (3×1032)					

Twin outboard chain assemblies

with complete flight bars to slag traps and other chain conveyors

Chain

- 24×86 grades FAS-UT, FAS-US or FAS-US EXTRA and others

Product manufacturing

Twin outboard chain assemblies to slag traps, used in the fuel and energy sector, are generally manufactured in segments of 5 and 7 links of paired, specially hardened chain 24×86 grade FAS-UT or FAS-US. The assemblies comprise wear-resistant flight bars and are mounted with locks 24×86, or they are assembled according to other individual designs.

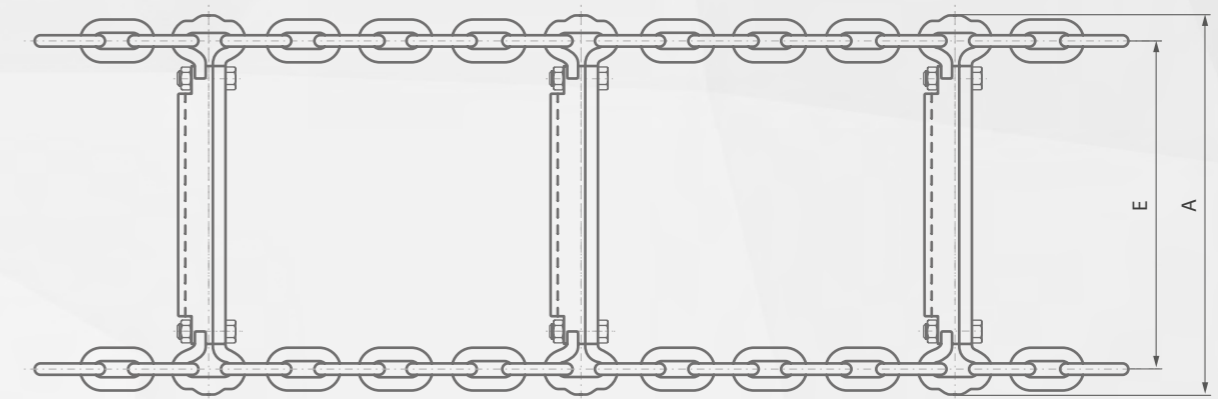

Dimensions

E and A acc. to the customer's specification

Twin outboard chain assemblies

to shuttle cars

Chain

- 18×64; two seven-link chain strands of grade FAS-UT, FAS-US or FAS-US EXTRA with exclusively designed flight bars or made according to individual construction

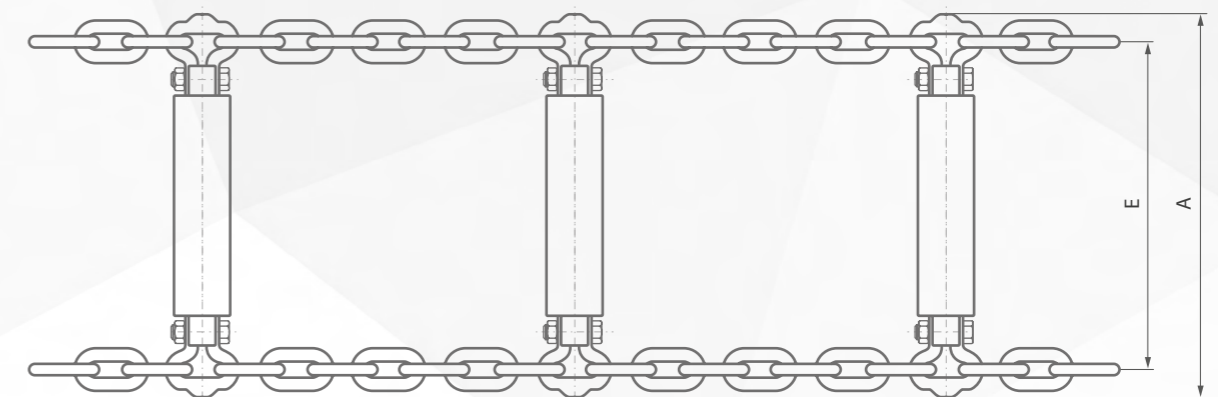

Dimensions

E and A acc. to the customer's specification

Twin outboard chain assemblies
for PZP GROT, SKAT, ŚLAŠK, SAMSON flight bar conveyors

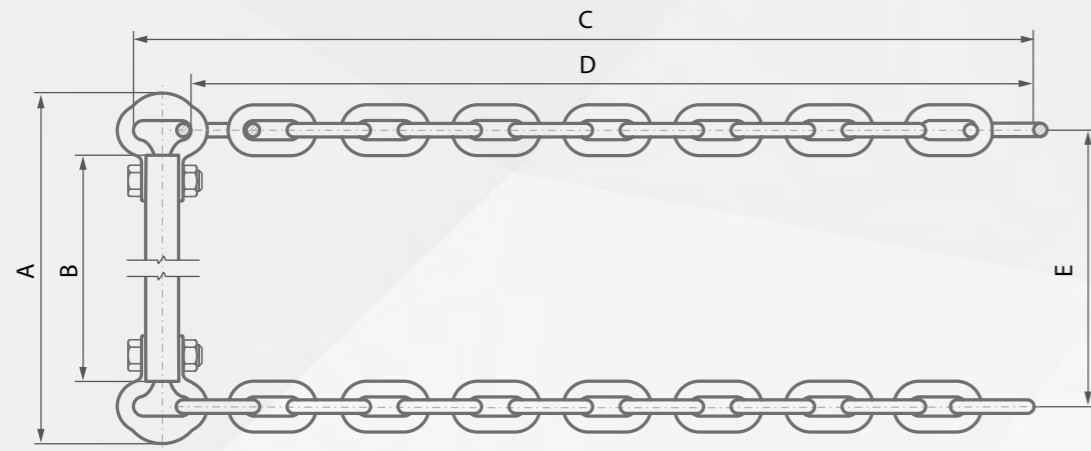

Lock type

Conveyor type	Chain assembly dimensions					Bolt	Nut	~Weight of one segment [kg]
	A [mm]	B [mm]	C [mm]	D [mm]	E [mm]			
PZP GROT - 67B - 720	690	544	1024	960	600	M20 × 80 - 10.9	M20 - 10	24.0
PZP GROT - 67B - 620	590	444	1024	960	500	M20 × 80 - 10.9	M20 - 10	22.5
PZ SKAT E 180 PZG 180	410	266	1024	960	320	M20 × 80 - 10.9	M20 - 10	20.2
PZ SKAT - 60/80	410	300	800	750	350	M16 × 65 - 8.8	M16 - 8	9.5

Conveyor type	Chain	Catalog no.				
		assembly	flight bar	lock	bolt	nut
PZP GROT - 67B - 720	18×64/15×2	618 07 022	618 00 202	618 00 200	POZ0012402	2640701011
PZP GROT - 67B - 620	19×64/15×2	618 08 022	618 01 202	618 00 200	POZ0012402	2640701011
PZ SKAT E 180 PZG 180	19×64.5/15×2	618 03 022	618 02 202	618 00 200	POZ0012402	2640701011
PZ SKAT - 60/80	14×50/15×2	614 01 022	614 01 202	614 00 200	POZ0012400	2640701031

At the request of the customer, the length of paired chain strands may be individually agreed upon.

Triple chain assemblies

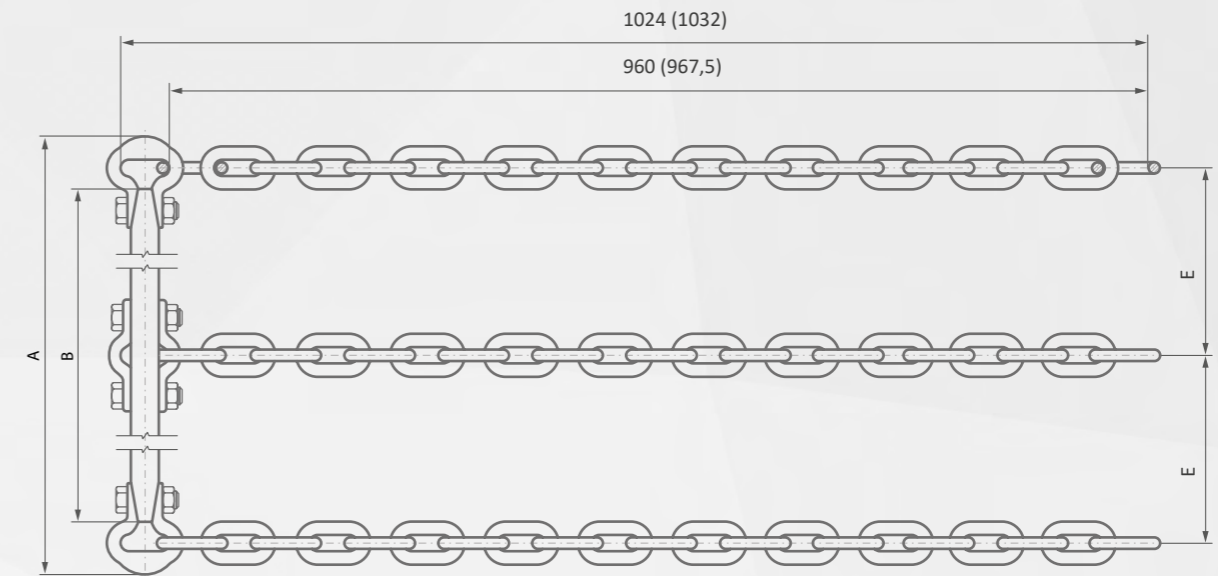

Conveyor type	Chain	Chain assembly dimensions			Bolt	Nut	~ Weight of one segment [kg]
		A [mm]	B [mm]	E [mm]			
PZS SAMSON - 67B - 742		690	544	300	M20 × 80 - 10.9	M20 - 10	30.0
PZS SAMSON - 67B - 720	18×64/15×2	690	544	300	M20 × 80 - 10.9	M20 - 10	30.0
PZS ŚLAŠK - 67B - 642	19×64/15×2	590	444	250	M20 × 80 - 10.9	M20 - 10	28.0
PZS ŚLAŠK - 67B - 620	(19×64.5/15×2)	590	444	250	M20 × 80 - 10.9	M20 - 10	28.0

Conveyor type	assembly	flight bar	Catalog no.			
			lock	clamp	bolt	nut
PZS SAMSON - 67B - 742	618 06 023	618 00 203				
PZS SAMSON - 67B - 720	618 06 023	618 00 203	618 00 200	618 02 203	POZ0012402	2640701011
PZS ŚLAŠK - 67B - 642	618 02 023	618 01 203				
PZS ŚLAŠK - 67B - 620	618 02 023	618 01 203				

At the request of the customer, the length of paired chain strands and chain center distance (total width) may be individually agreed upon.

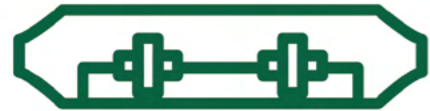

Flight bars, clamps, locks

FASING is a producer of all accessories to chain assemblies:

- forged flight bars of increased wear resistance for outboard and inboard chain assemblies,
- locks made acc. to DIN 22253 and PN-G-46696,
- forged and bent clamps.

All accessories meet the highest quality and strength requirements thanks to carrying out the inspection at every stage of the production process.



Flight bars

made acc. to DIN 22259

For inboard chain assemblies, FASING offers flight bars of strengthened, symmetric design to be applied in armored face conveyors and beam stage loaders. They cooperate with round and flat link chains. Manufacturing forged flight bars of chromium-molybdenum steel, and the use of special heat treatment guarantee a higher value of impact toughness in comparison to the requirements included in DIN 22259 standard. Due to the patented solution of fitting the clamp into a flight bar, which is connected with high-quality bolts and self-locking nuts, the flight bars are of increased durability with no risk of clamp loosening in time of operation.

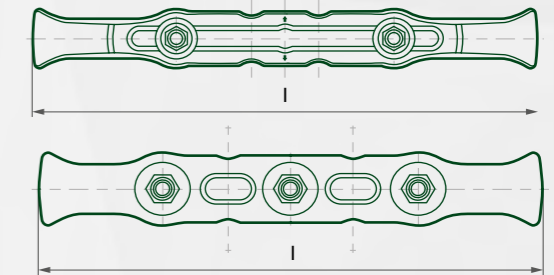
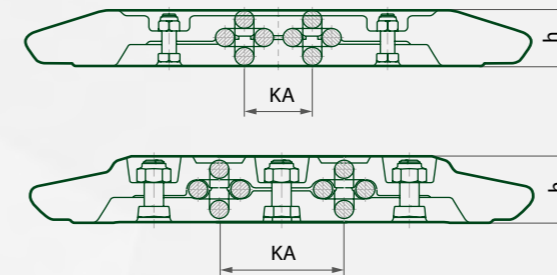

Dimensions and application

Chain size	Product reference	Profile	Hole centres KA	Length l	Height h	~Weight
[mm]			[mm]	[mm]	[mm]	[kg]
26×92	104 - 622 R	DH 726 K	200	685	97.0	29.0
26×92	2 × 26 × 92 - 120	Rybnik - 750/E-230	120	690	93.5	21.0
26×92	104 - 104	PF3.26/600	600	714	110.0	38.6
26×92	104 - 1021 R	222 × 1064	375	1 012	89.0	47.4
30×108	103 - 329 B	PF2.30 - 732	115	672	103.0	28.1
30×108	104 - 121	375/1012/30	375	1 012	104.0	56.0
30×108	103 - 329 P	3HB260	130	699	110.0	29.1
30×108	009 - P	Rybnik - 750E-230	140	690	104.0	23.4
30×108	104 - 831 R	222 × 824	200	812	104.0	38.0
30×108	104 - 631	3HB - 260	1 nitka	672	98.0	24.5
30×108	103 - 451 AS	KSJU - 381	140	786	110.0	49.0
30×108	104 - 731R	DH 726	195	786	115.0	38.0
30×108	103 - 624	Rybnik 750 E230	140	690	103.0	24.5
34×126	103 - 311 CZ/1	PF4 - 932	145	776	113.0	34.2
34×126	103 - 311 P	4HB260	150	779	112.0	35.8
34×126	103 - 375 K	PF2.30 - 732	130	676	115.0	35.1
34×126	103 - 426	PF280/1100	330	1 015	112.0	47.3
34×126	103 - 441 R	PF4/5 - 1332	330	1 172	115.0	55.3
34×126	103 - 444 R	PF4 - 1032	150	876	115.0	47.2
34×126	105 - 104	34/1200	500	1 186	126.0	84.3
34×126	105 - 121	PF4 - 1532	330	1 372	115.0	78.9
34×126	104 - 711	150/781/34	146	781	113.0	35.2
34×126	103 - 229 B	E74V/E82	1 nitka	672	110.0	30.8
34×126	104 - 845 R	KSJ 391	200	876	116.0	46.4
34×126	104 - 849 R	GROT - 950	150	865	118.0	45.3
34×126	104 - 1131 R	HB280/1200	150	1 115	110.0	64.4
34×126	103 - 455 M	200/888/34	200	888	115.0	47.0
34×126	104 - 702	PF4 - 932	145	774	113.0	36.0
34×126	103 - 470 ABR	PF4 - 1132	130	976	115.0	54.0

Dimensions and application

Chain size [mm]	Product reference	Profile	Hole centres KA [mm]	Length l [mm]	Height h [mm]	~Weight [kg]
34x126	103 - 455 P	298/800/BB	200	786	115	
34x126	104 - 741 R	KSU - 381	170	781	110	49.0
38x126	105 - 1252	500/1280/38	500	1 280	117	84.2
38x126	105 - 125	1350-500	500	1 336	126	94.3
38x126	104 - 788	Rybnik - 850 E260	190	776	113	36.1
38x126	105 - 392	1000-L8-240/988/38	240	988	94	46.0
38x126	104 - 885 R	E265-FFC-9	180	885	115	45.0
38x126	104 - 130 R	Rybnik 1100	190	1 004	125	59.0
38x137	104 - 881 M	170/884/38	170	884	115	47.0
38x137	103 - 446-1	HB280V-1000	190	915	115	47.2
38x137	104 - 787 R	AT/298/800/BB	200	782	117	39.1
42x146	103 - 446	HB280V/1000	200	915	115	47.1
42x146	103 - 449 A	PF4-1132	165	972	115	54.2
42x146	104 - 843	TH/200/878/42	200	878	127	50.0
42x146	105 - 124	1000-222-200/985/42	220	985	126	64.4
42x146	104 - 470 ABF	FFC-9/E265	165	880	112	47.2
42x146	104 - 470 ABL	PF4-1032	165	873	117	48.0
42x146	105 - 114	900-268	200	885	120	51.5
42x146	103 - 455	PF280-880	200	795	115	42.8
42x146	103 - 457 A	PF4-1332	165	1 172	115	65.8
42x128/164	105 - 158	280/988/42	280	988	106	61.3
48x144/160	104 - 651	HB227/732	1 nitka	672	121	31.7
48x144/160	103 - 450 A/D	PF4-1132	250	976	130	68.9
48x152	105 - 109	PF5 - 1332	250	1 176	133	77.2
48x152	105 - 123/1	260-280/986/48	280	986	136	74.6
48x152	105 - 156	1250-268-200/1238/48	280	1 238	136	83.4
48x152	1086 - 139	280/1086/48	280	1 086	139	73.8
48x152	105 - 109 a	250/1076/48	250	1 076	136	73.9
48x152	103 - 460 M	250/988/48	250	988	131	64.0
50x146/174	105 - 128-BB-50	280/988/50	280	988	136	75.0
56x168/204	105 - 130-BB	320/1088/56	320	1 088	156	109.3
60x181/197	106 - 1300	330/1388/60	330	1 388	162	154.0

Others made acc. to individual designs.

Flight bars for twin outboard chain assembly

with locks

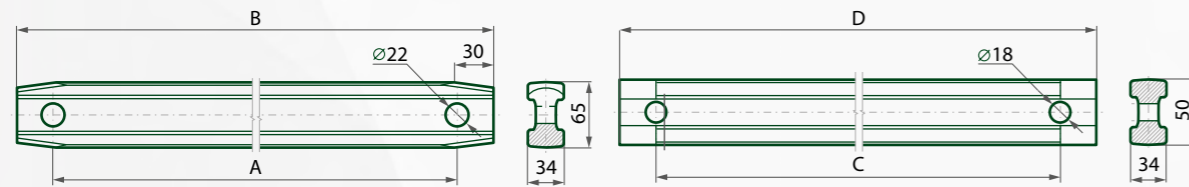

Conveyor type	Flight bar dimensions				~Weight [kg]	Catalog no.
	A [mm]	B [mm]	C [mm]	D [mm]		
PZP GROT - 67B - 720	490	544	-	-	7.3	618 00 202
PZP GROT - 67B - 620	390	444	-	-	5.7	618 01 202
PZ SKAT E 180	210	266	-	-	3.2	618 02 202
PZ SKAT - E - 60/80	-	-	248	300	2.5	614 01 202

Flight bars for twin outboard chain assembly

non-lock type

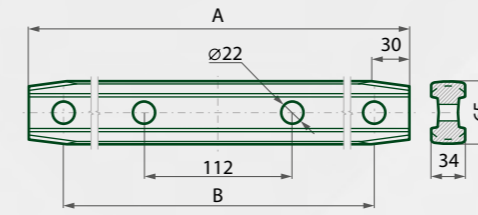

Conveyor type	Flight bar dimensions			Catalog no.
	A [mm]	B [mm]	~Weight [kg]	
PZP SAMSON - 67B - 742	544	490	7.2	618 00 203
PZP SAMSON - 67B - 720	544	490	7.2	618 00 203
PZ SLASK - 67B - 642	444	390	5.6	618 01 203
PZ SLASK - 67B - 620	444	390	5.6	618 01 203

Flight bars for triple chain assemblies and drilled

Drilled forged clamp

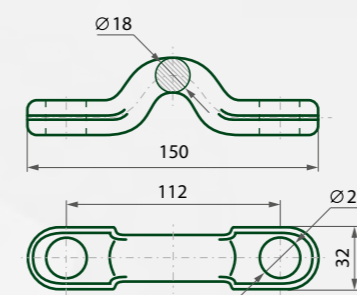

Bended clamp

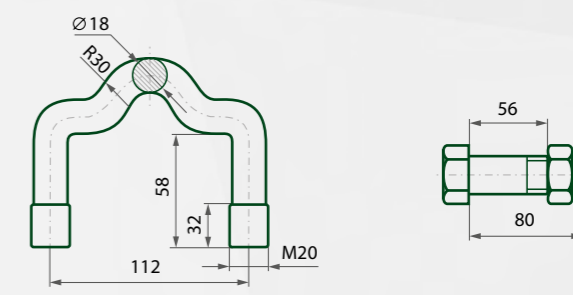

	Drilled forged clamp and drilled	Bended clamp	Bolt M20 x 80-10.9	Nut M20 - 10 - B
~ Weight [kg]	0.30	0.50	0.26	0.06
Catalog no.	61802203	61803203	POZ0012402	2640701011

Locks for double and triple chain assemblies

with chamfered arms DIN 22253 and arms without chamfers PN-G-46696

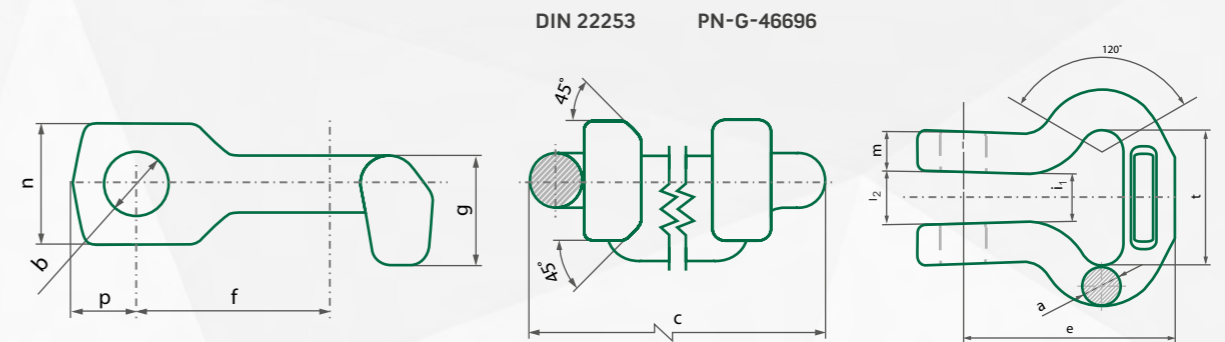

Locks acc. to DIN 22253 standard (FORM-B lock type)

Lock dimensions [mm]	a [mm]	t [mm]	c [mm]	b [mm]	e ⁺¹ ₋₂ [mm]	l ₁ [mm]	l ₂ [mm]	m ⁰ ₋₁ [mm]	n ⁰ ₋₁ [mm]	p ⁺¹ ₀ [mm]	f ⁺¹ _{0,5} [mm]	g ⁻¹ _{1,5} [mm]
14x50.0	15 ^{+0,7} _{-0,5}	50.0 ^{+0,8} _{-0,3}	79 ± 1	17+0.5	78	17.5 ⁺¹ ₀	l _{1st} ^{+1,5} ₀	15	32	17	51	29
18x64.0	19 ^{+1,0} _{-0,5}	64.0 ^{+0,9} _{-0,3}	101 ± 1	21+0.5	100	20.5 ⁺¹ ₀	l _{1st} ^{+1,5} ₀	19	43	37	55	40
19x64.5	20 ^{+1,0} _{-0,5}	64.5 ^{+0,9} _{-0,3}	105 ± 1	21+0.5	100	20.5 ⁺¹ ₀	l _{1st} ^{+1,5} ₀	20	43	37	55	41
22x86.0	23 ^{+1,0} _{-0,5}	86.0 ^{+1,3} _{-0,4}	132 ± 2	25+1.0	133	24.5 ⁺¹ ₀	l _{1st} ^{+1,5} ₀	23	52	44	75	46
24x86.0	25 ^{+1,0} _{-0,5}	86.0 ^{+1,3} _{-0,4}	136 ± 2	25+1.0	133	26.0 ⁺¹ ₀	l _{1st} ⁺² ₀	25	53	44	78	55
26x92.0	27 ^{+1,0} _{-0,5}	92.0 ^{+1,4} _{-0,5}	146 ± 2	28+1.0	141	28.0 ^{+1,5} ₀	l _{1st} ⁺² ₀	27	58	44	85	56
30x108.0	32 ^{+1,0} _{-0,5}	108.0 ^{+1,6} _{-0,5}	172 ± 2	31+1.0	159	32.0 ^{+1,5} ₀	l _{1st} ⁺² ₀	32	70	44	100	59

Locks acc. to PN-G-46696 standard (non-chamfered arms lock type)

Lock dimensions [mm]	a (d ₁) [mm]	t ₂ ⁰ (a) [mm]	c ⁺² [mm]	b (d ₂) [mm]	e ⁺¹ ₋₂ (l) [mm]	l ₁ (V) [mm]	l ₂ (V ₁) [mm]	m ⁰ ₋₁ (t) [mm]	n ₋₂ (s) [mm]	p ^(w) _{min.} [mm]	f ± 1 (e) [mm]	g ⁰ _{-2,5} (f) [mm]
14x50	15 ^{+1,0} _{-0,5}	50	80	17 ^{+0,5}	81	18 ⁺²	l ₁ ^{+1,5}	15.0	27.0	15	51	35
18x64	19 ^{+1,5} _{-0,5}	64	103	21 ^{+0,5}	99	21 ⁺²	l ₁ ⁺³	17.5	32.8	25	55	39

Mechanical properties of locks

Lock dimensions [mm]	Test force			Breaking force		
	Grade B PN-G-46696 [kN]	Grade C PN-G-46696 [kN]	DIN 22253 [kN]	Grade B PN-G-46696 [kN]	Grade C PN-G-46696 [kN]	DIN 22253 [kN]
14x50.0*	135	180	185	170	225	212
18x64.0*	230	300	305	290	370	351
19x64.5	260	325	340	325	405	391
22x86.0	-	440	456	-	550	525
24x86.0	410	490	507	510	650	588
26x92.0	-	-	595	-	-	690
30x108.0	-	-	750	-	-	869

Specification of bolts and nuts for locks

Lock dimensions [mm]	Bolt		Nut		Torque applied to a nut [Nm]	~Weight [kg]
	Type	Grade	Type	Grade		
14x50.0*	M16 × 70	8.8	M16	8	220	0.8
18x64.0*	M20 × 90	10.9	M20	10	600	1.6
19x64.5	M20 × 90	10.9	M20	10	600	1.6
22x86.0	M24 × 110	10.9	M24	10	1 000	2.9
24x86.0	M24 × 110	10.9	M24	10	1 000	3.2
26x92.0	M27 × 120	10.9	M27	10	1 500	3.8
30x108.0	M30 × 140	10.9	M30	10	2 100	6.4

Locks of other sizes and parameters are available following the individual agreements with a customer.

*it is possible for the locks to be manufactured with arms without chamfers acc. to PN-G-46696 standard



Connecting links

FASING offers a wide range of connecting links that are suited to specific performance conditions and the applied chains. The connecting links can work in a horizontal position (OZPZR), vertical position (OZBR) or they can work in both positions as universal links (OZUS and OZUZR). The special heat treatment applied, and the machining performed in the latest machining centers guarantee increased, more effective mechanical and performance parameters in comparison to the requirements included in DIN 22258 standard. Moreover, it ensures fast and easy assembly and disassembly of connecting links while maintaining high product quality and reliability.

ⓘ Mechanical properties of the connecting links OZUZR, OZUS, OZPZR, OZBR, which are included in DIN 22258-1, DIN 22258-2, DIN 22258-3 standards and by considering the Rebinder effect, regard the surface after technical production process (without scales) in dry, non-oily condition, without any coatings.

OZUS

Universal Bolt-type Connecting Links
acc. to DIN 22258-1, PN-G-46705, MT/T 99
and FASING Technical Requirements

Application

For connecting round link chains (in vertical and horizontal position), mining flat link chains (in horizontal position only) and other chains upon agreement with FASING. OZUS connecting links undergo qualification testing in 100%. The tests consist of test force application to the links in the value of ~75% to ~90% of breaking force.

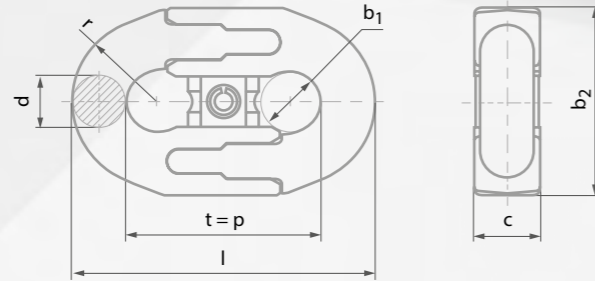

Dimensions

Link size d × t (p)	d	t = p	b ₁ min.	b ₂ max.	c max.	l max.	r %	~ Weight
[mm]	[mm]	[mm]	[mm]	[mm]	[mm]	[mm]	[mm]	[kg]
18×64	18	64	20	72	22	102	28	0.7
22×86	22	86	24	84	28	132	34	1.2
24×86	24	86	26	83	30	136	37	1.6
26×92	26	92	28	96	32	146	40	1.9
30×108	30	108	32	109	36	170	46	2.9
34×126	34	126	38	121	41	196	52	4.2
38×126	38	126	42	137	46	206	59	5.3
38×137	38	137	42	134	46	217	59	5.7
42×146	42	146	45	151	53	235	67	7.0
42×152*	42	152	44	150	51	238	64	7.2

For all types of connecting links there are appropriate strength grades:

PN-acc. to PN-G-46705, DIN-acc. to DIN 22258-1 and PW, D, D-MAX acc. to FASING Technical Requirements, DIN 22258-1 and PN-G-46705

Mechanical properties

Link size d × t (p)	Test force		Breaking force		Fatigue resistance	PW			D		
	PN	DIN	PN	DIN		Test force	Breaking force	Fatigue resistance	Test force	Breaking force	Fatigue resistance
[mm]	[kN]	[kN]	[kN]	[kN]	[cykle]	[kN]	[kN]	[cykle]	[kN]	[kN]	[cykle]
18×64	330	305	370	361	40 000	330	410	50 000	370	460	50 000
22×86	490	456	550	540	40 000	490	610	50 000	540	680	50 000
24×86	580	543	650	642	40 000	580	720	50 000	650	810	50 000
26×92	640	637	770	754	70 000	640	850	80 000	770	960	80 000
30×108	850	848	1 020	1 000	70 000	850	1 150	80 000	1 020	1 270	80 000
34×126	1 080	1 090	1 310	1 290	70 000	1 080	1 450	80 000	1 300	1 630	80 000
38×126	1 360	1 360	1 630	1 610	70 000	1 360	1 800	80 000	1 630	2 040	80 000
38×137	1 360	1 360	1 630	1 610	70 000	1 360	1 800	80 000	1 630	2 040	80 000
42×146	1 660	1 660	2 000	1 970	70 000	1 660	2 210	80 000	1 990	2 490	80 000
42×152*	1 660	1 660	2 000	1 970	70 000	1 660	2 210	80 000	1 990	2 490	80 000

Acceptable work force and working load limit (WLL, WF) should not exceed 70% of breaking force value and should be consistent with appropriate standard DIN 22258-1, DIN 22252 or DIN 22255 for chains and/or consistent with FASING requirements and guidelines. Other chain sizes e.g. 26×100, 30×120, 34×136, 38×144 are available following the individual agreements with a customer.

* to be produced

OZUZR

Universal Lock-type Rapid Connecting Links
(fast assembly and disassembly)
acc. to DIN 22258-1, PN-G-46705, MT/T 99
and FASING Technical Requirements

Application

For connecting round link chains (in vertical and horizontal position), mining flat link chains (in horizontal position only) and other chains upon agreement with FASING. OZUZR connecting links undergo qualification testing in 100%. The tests consist of test force application to the links in the value of ~75% to ~85% of breaking force.

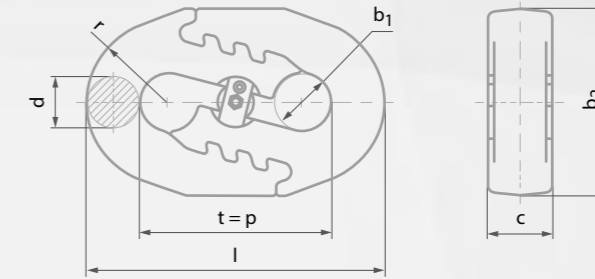

Dimensions

Link size d × t (p)	d	t = p	b ₁ min.	b ₂ max.	c max.	l max.	r %	~ Weight
[mm]	[mm]	[mm]	[mm]	[mm]	[mm]	[mm]	[mm]	[kg]
18×64*	18	64	20	72	24	102	27	0.7
22×86*	22	86	24	84	28	132	34	1.3
24×86*	24	86	26	85	30	136	37	1.5
26×92	26	92	29	96	33	146	40	2.0
30×108	30	108	33	109	36	170	46	3.0
34×126	34	126	37	121	41	196	52	4.3
38×126	38	126	41	137	46	204	59	5.4
38×137	38	137	41	134	46	215	59	5.8
38×146	38	146	41	137	46	224	59	6.1
42×146	42	146	45	150	53	235	65	7.4

For all types of connecting links there are appropriate strength grades:

PN-acc. to PN-G-46705, DIN-acc. to DIN 22258-1 and PW, D, D-MAX acc. to FASING Technical Requirements, DIN 22258-1 and PN-G-46705

Mechanical properties

Link size d × t (p)	Test force					Breaking force					Fatigue resistance 50 - 250 [MPa], min. and acc. to DIN 22258-1	
	PN	DIN	PW	D	D-MAX	PN	DIN	PW	D	D-MAX	PN=DIN	PW, D, D-MAX
[mm]	[kN]	[kN]	[kN]	[kN]	[kN]	[kN]	[kN]	[kN]	[kN]	[kN]	[cykle]	[cykle]
18×64*	330	305	330	420	460	370	361	410	480	520	40 000	50 000
22×86*	490	456	490	640	680	550	540	610	715	770	40 000	50 000
24×86*	580	543	580	760	810	650	642	720	845	910	40 000	50 000
26×92	640	637	640	830	900	770	754	850	1 000	1 080	70 000	80 000
30×108	850	848	850	1 100	1 190	1 020	1 000	1 150	1 330	1 430	70 000	80 000
34×126	1 080	1 090	1 080	1 400	1 500	1 310	1 290	1 450	1 690	1 820	70 000	80 000
38×126	1 360	1 360	1 360	1 770	1 900	1 630	1 610	1 800	2 120	2 290	70 000	80 000
38×137	1 360	1 360	1 360	1 770	1 900	1 630	1 610	1 800	2 120	2 290	70 000	80 000
38×146	1 360	1 360	1 360	1 770	1 900	1 630	1 610	1 800	2 120	2 290	70 000	80 000
42×146	1 660	1 660	1 660	2 160	2 330	2 000	1 970	2 210	2 560	2 760	70 000	80 000

Other sizes of connecting links, e.g. 26×100, 30×120, 34×136, 38×144 available following the individual agreements with a customer.

* to be produced

OZPZR
Horizontal Lock-type
Rapid Connecting Links
(fast assembly and disassembly)
acc. to DIN 22258-2
and FASING Technical Requirements



Application
For connecting round link chains, mining flat link chains and others upon agreement with FASING. OZPZR shape makes it suitable to work in a horizontal position only.

ⓘ OZPZR Horizontal Connecting Links will operate with conveyor sprockets only if assembled in horizontal plane.

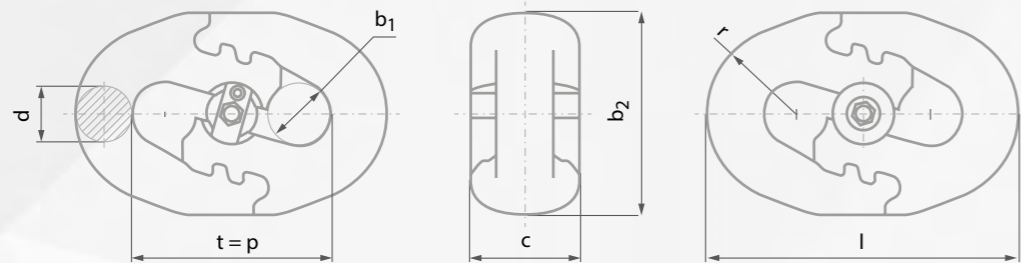

Dimensions

Link size d × t (p)	d	t = p	b ₁ min.	b ₂ max.	c max.	l max.	r ±%	~Weight
[mm]	[mm]	[mm]	[mm]	[mm]	[mm]	[mm]	[mm]	[kg]
26×92*	26	92	28	96	50	147	40	2.8
30×108	30	108	33	111	62	168	46	3.7
34×126	34	126	37	121	74	194	52	5.3
38×126	38	126	42	134	79	206	59	7.3
38×137	38	137	42	134	79	217	59	7.5
38×146	38	146	42	134	79	226	59	7.7
42×146	42	146	47	148	84	234	65	10.5

For all types of connecting links there are appropriate strength grades:
PN-acc. to PN-G-46705, DIN-acc. to DIN 22258-2 and D, D-MAX acc. to FASING Technical Requirements, DIN 22258-2 and PN-G-46705

Mechanical properties

Link size d × t (p)	Test force			Breaking force			Fatigue resistance 50 - 250 [MPa], min. and acc. to DIN 22258-2		
	DIN	D	D-MAX	DIN	D	D-MAX	DIN	D	D-MAX
[mm]	[kN]	[kN]	[kN]	[kN]	[kN]	[kN]	[cycle]	[cycle]	[cycle]
26×92*	637	830	900	850	1 000	1 080	70 000	80 000	80 000
30×108	848	1 100	1 190	1 130	1 330	1 430	70 000	80 000	80 000
34×126	1 090	1 400	1 500	1 450	1 690	1 820	70 000	80 000	80 000
38×126	1 360	1 770	1 900	1 820	2 120	2 290	70 000	80 000	80 000
38×137	1 360	1 770	1 900	1 820	2 120	2 290	70 000	80 000	80 000
38×146	1 360	1 770	1 900	1 820	2 120	2 290	70 000	80 000	80 000
42×146	1 660	2 160	2 330	2 220	2 560	2 760	70 000	80 000	80 000

*to be produced

OZUZR-S
Universal Lock-type
Rapid Connecting Links for Plows
(fast assembly and disassembly)
acc. to DIN 22258-1
and FASING Technical Requirements



Application
For connecting plow round link chains acc. to DIN 22252, which work at speed of up to 3.6 m/s. Innovative construction connecting links are adjusted to the chain geometry, which ensures their optimal use in the mining plow.

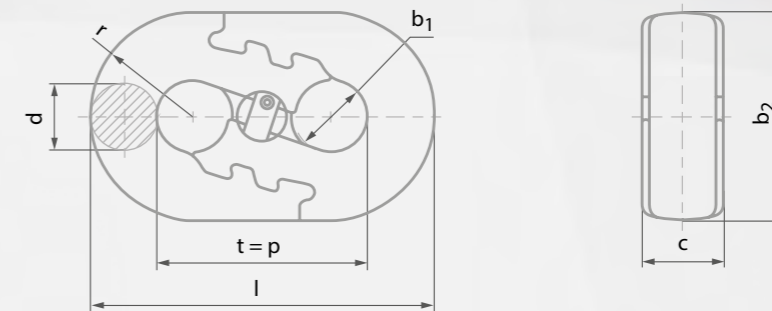

Dimensions

Link size d × t (p)	d	t = p	b ₁ min.	b ₂ max.	c max.	l max.	r ±%	~Weight
[mm]	[mm]	[mm]	[mm]	[mm]	[mm]	[mm]	[mm]	[kg]
38×137	38	137	42	121	46	217	61	5.5
42×137	42	137	47	137	53	226	67	7.3

Mechanical properties

Link size d × t (p)	Test force DIN	Breaking force DIN	Fatigue resistance 50 - 250 [MPa], min. and acc. to DIN 22258-1
[mm]	[kN]	[kN]	[cycles]
38×137	1 360	1 610	70 000
42×137	1 660	1 970	70 000

OZBR
Block-type
Rapid Connecting Links
(fast assembly and disassembly)
acc. to DIN 22258-3
and FASING Technical Requirements



Application
For connecting round chain links acc. to DIN 22252 and flat chain links acc. to DIN 22255 in a vertical position. Due to massive and fit construction, OZBR connecting links guarantee the following: the possibility of installation in any direction of work, fast assembly and disassembly at the increased strength parameters and performance durability.

ⓘ OZBR Block Connecting Links can work in sprockets that are made acc. to DIN 22256, in vertical position only.

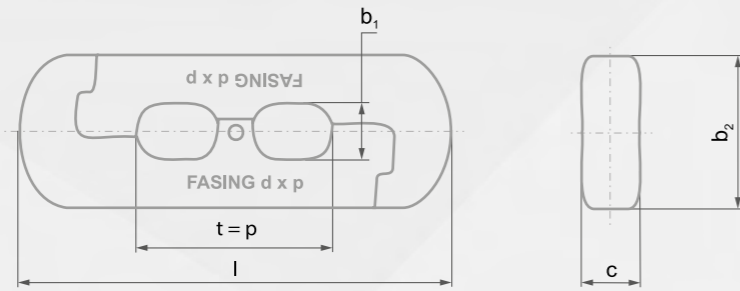

Dimensions and mechanical properties

Link size $d \times t (p) - b_2$	$t = p$	l max.	c max.	b_1 min.	b_2 max.	Breaking force min.	~Weight
[mm]	[mm]	[mm]	[mm]	[mm]	[mm]	[kN]	[kg]
34×126-84	126	284	36	37	84	1 500	5.6
34×126-98	126	284	36	37	98	1 610	6.4
38×126-101	126	275	40	41	101	1 910	7.0
38×126-107	126	275	40	41	107	2 010	7.5
38×137-101	137	307	40	41	101	1 910	8.0
38×137-107	137	307	40	41	107	2 010	8.6
42×146-109	146	329	45	45	109	2 510	10.0
42×146-114	146	329	45	45	114	2 510	10.4
48×144	144	336	56	52	115	2 900	12.3
48×152-115	152	336	56	52	115	2 910	11.8
48×152-121	152	336	56	52	121	2 910	12.7
48×152-125	152	336	56	52	125	3 110	13.0
52×170-125	170	366	61	55	125	3 400	16.0
56×187	187	402	66	62	131	4 010	20.0
60×181	181	402	70	65	135	4 520	22.4

*Fatigue resistance acc. to DIN 22258-3

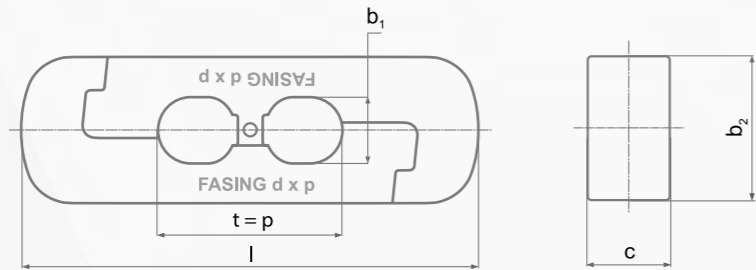

Dimensions and mechanical properties - OZBR for Solid Profile

Link size $d \times t (p) - b_2$	d	$t = p$	l max.	c max.	b_1 min.	b_2 max.	Breaking force min.	~Weight
[mm]	[mm]	[mm]	[mm]	[mm]	[mm]	[mm]	[kN]	[kg]
OZBR SP 38×126	38	126	308	54	40	88	2 010	8.2
OZBR SP 42×128	42	128	315	60	44	99	2 510	11.3
OZBR SP 50×146	50	146	356	65	52	115	3 400	14.5
OZBR SP 56×168	56	168	390	75	61	130	3 940	22.8

*Fatigue resistance acc. to DIN 22258-3

The following connecting links: OZUS, OZUZR, OZPZR, OZBR, OZUZR-S are delivered as an assembled piece with tools for their assembly/disassembly, i.e. (depending on the type of a connecting link) – pin punches, special wrenches or hex wrenches acc. to ISO 2936 and DIN 911.



Wear resistant round link chains

Wear resistant round link chains: hardened technical UT chains, hardened special US chains, case hardened technical NT chains and case hardened special NS chains.

Characteristics

- geometry consistent with DIN 22252 standard
- higher wear resistance
- higher mechanical properties
- variable hardness in one link for FAS-US EXTRA (grade 11)
- optimal for stone transport

Application

- flight bar conveyors
- road headers
- bucket elevators
- pipe conveyors

Industry branches

- mining industry
- power industry
- sugar industry
- agriculture
- food industry

FAS-US

Wear resistant round link chains.
Hardened, special.

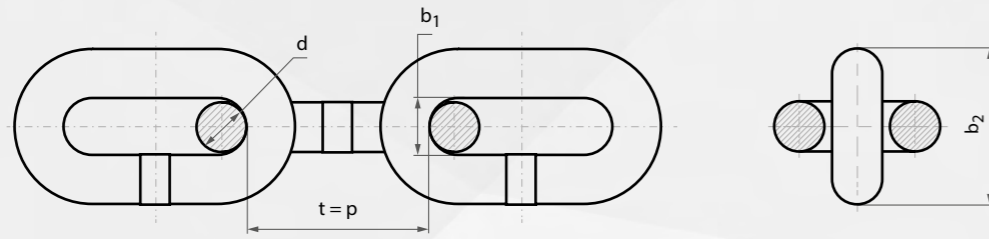

Dimensions and mechanical properties

Chain size d × t (p)	b ₁ min.	b ₂ max.	Test force	Breaking force min.	Deflection f min.	~Weight
[mm]	[mm]	[mm]	[kN]	[kN]	[mm]	[kg/m]
14×50	17	48	193	310	14	4.0
18×64	21	60	320	510	18	6.6
19×64/64.5	22	63	360	565	19	7.4
22×86	26	73	480	760	22	9.5
24×86/87.5	28	79	570	900	24	11.6 / 11.5
26×92	30	85	670	1 060	26	13.7
30×108	34	97	890	1 400	30	18.0
34×126	38	110	1 140	1 800	34	22.7
38×126/137/146	42	122	1 430	2 270	38	30.1 / 29.0 / 27.6
42×137	48	139	1 740	2 770	42	36.9
42×146	48	137	1 740	2 770	42	36.0

Unit elongation at test force max. 1.6%. Unit elongation at breaking force min. 12%.

FAS-USŁ

Wear resistant round link chains.
Crown hardened, special - annealed.

Dimensions and mechanical properties

Chain size d × t (p)	b ₁ min.	b ₂ max.	Grade 9			
			Test force	Breaking force min.	Deflection f min.	~Weight
[mm]	[mm]	[mm]	[kN]	[kN]	[mm]	[kg/m]
18×64	21	60	229	458	18	6.6
19×64.5	22	63	255	510	19	7.4
22×86	26	73	342	684	22	9.5
24×86/87.5	28	79	407	814	24	11.6 / 11.5
26×92	30	85	478	956	26	13.7
26×100	31	87	478	956	26	13.3
30×108	34	97	636	1 272	30	18.0
34×126	38	110	817	1 634	34	22.7
34×136	39	113	817	1 634	34	22.5

Unit elongation at test force max 1.6%. Unit elongation at breaking force min. 12%.

FAS-USŁ chains (grade 9) are produced in the hardness range of:
at crowns 375÷400 HBW; at legs 328÷352 HBW.

Other grades of FAS-USŁ chains (grades 6 and 8) are available at the customer's request and following the individual agreements with the customer.

FAS-US EXTRA

Wear resistant round link chains.
Hardened, special.

Characteristics

Round link chains of increased strength and higher wear resistance, particularly at link crowns. The chains are to be used, according to specialist expertise, in the performance conditions where the standard chains of grade C, acc. to DIN 22252 and/or PN-G-46701, have decreased durability as a result of: fast surface wear in operating chain link crowns, fast increase in deflection value and, as a result, the need of chain replacement because of non-cooperation with sprockets. It is advised to use FAS-US EXTRA chains with FASING flight bars of appropriate design and parameters (complete chain assembly). FAS-US EXTRA chains are manufactured according to the technical and production process, DIN 22252 and/or PN-G-46701 standards and FASING Technical Requirements.

Dimensions and mechanical properties

Chain size d × t (p)	b ₁ min.	b ₂ max.	Test force	Breaking force min.	Deflection f min.	~ Weight
[mm]	[mm]	[mm]	[kN]	[kN]	[mm]	[kg/m]
14×50	17	48	215	340	14	4.0
18×64	21	60	360	560	18	6.6
19×64/64.5	22	63	400	625	19	7.4
22×86	26	73	530	840	22	9.5
24×86/87.5	28	79	630	995	24	11.6 / 11.5
26×92	30	85	740	1 170	26	13.7
30×108	34	97	990	1 555	30	18.0
34×126	38	110	1 270	2 000	34	22.7
38×126/137/146	42	122	1 550	2 495	38	30.1 / 29.0 / 27.6

Unit elongation at test force max. 1.4%. Unit elongation at breaking force min. 14%.

FAS-UT

Wear resistant round link chains.
Hardened, technical.

Dimensions and mechanical properties

Chain size d × t (p)	b ₁ min.	b ₂ max.	Test force	Breaking force min.	Deflection f min.	~ Weight
[mm]	[mm]	[mm]	[kN]	[kN]	[mm]	[kg/m]
14×50	17	48	185	280	11	4.0
18×64	21	60	305	460	14	6.6
19×64/64.5	22	63	340	510	15	7.4
22×86	26	73	456	680	18	9.5
24×86/87.5	28	79	543	815	19	11.6 / 11.5
26×92	30	86	637	960	21	13.7
30×108	34	98	848	1 270	24	18.0
34×126	38	110	1 090	1 650	27	22.7
38×126/137/146	42	122	1 360	2 040	30	30.1 / 29.0 / 27.6
42×146	48	137	1 660	2 500	33	36.0

Unit elongation at test force max. 1.6%. Unit elongation at breaking force min. 8%. Other chain sizes FAS-US, FAS-USŁ, FAS-US EXTRA, FAS-UT available following the individual agreements with a customer.

Application

FAS-US EXTRA chains of grade 11 (≥ 1100 MPa) are used in mining chain conveyors, AFCs and other types of conveyors, gangway loaders in road headers; and in the environment with stone presence.

Operation durability of FAS-US EXTRA chains under the following conditions i.e. proper wear degree, fitting flight bar and sprocket design, proper control of initial chain tension, is two, three and more times longer in comparison to the standard chains of grade C, acc. to DIN 22252 and/or PN-G-46701, and 20-25% longer than the durability of FAS-US chains.

FAS-NT

Wear resistant round link chains.
Case hardened, technical.

Application

Used in equipment for which high wear resistance of chains is required.

Mechanical properties

Mechanical properties of case hardened chains depend on the carburizing depth. The depth can reach up to max. 14% of bar diameter. The deeper the carburizing, the smaller breaking force is observed. The unit elongation at breaking force is only 1.5 ÷ 3%.

Depending on carburizing depth, the chains are manufactured in two group types:

group A

total carburizing depth within the range:
 $(9 \div 7\%) d$ $(0.09 \div 0.07) \times d$

group B

total carburizing depth within the range:
 $(14 \div 10\%) d$ $(0.14 \div 0.10) \times d$

(d - chain diameter)

The surface hardness of case-hardened chains is ca. 800 HV (64 HRC). The hardness of the core (beyond the carburizing level) in FAS-NS chains is min. 400 HV (380 HBW; 40.8 HRC) – 5% decrease in hardness is acceptable – its value is two times higher than the core hardness of FAS-NT chains, which is min. 200 HV (190 HBW) – 5% decrease in hardness is acceptable.

⚠ Due to production technology, the case-hardened chains are hard and brittle. An equipment designer should take into account the maximum (the highest possible) safety factor value for working load limit (WLL) in the kinematic and dynamic system. Improper use of chain (exceeding WLL) may cause chain breaking in a brittle manner with link falling into small pieces. Their significant force may jeopardize the safety and health of workers who are in the immediate vicinity of the chain operation area.

Case-hardened chains can be loaded only with a force that is longitudinal to the chain axis. It is unacceptable to:

- weld any elements to chain links,
- load the chain links with a lateral force that spreads the link from the inside or load them with a compressive force that acts from the outside,
- load the chain links with impact forces, strokes.

Stress at breaking force based on carburizing depth

Group of case-hardened chains	Total depth	Hardening depth after carburizing	Stress at breaking force	
			FAS-NT chain	FAS-NS chain
		[min. 550 HV]	[N/mm ² , MPa]	[N/mm ² , MPa]
A	[9 ÷ 7%] d	[5 ÷ 3%] d	280 ÷ 310	400 ÷ 450
B	[14 ÷ 10%] d	[10 ÷ 6%] d	240 ÷ 270	350 ÷ 400

FAS-NS

Wear resistant round link chains.
Case hardened, special.

Application

Used in conditions for which both high wear resistance and relatively high strength properties are required.

Dimensions and mechanical properties

Chain size d × t (p)	b ₁ min.	b ₂ max.	Test force		Breaking force				~Weight [kg/m]
			FAS - NT Group A and B	FAS - NS Group A and B	FAS - NT Group A	FAS - NT Group B	FAS - NS Group A	FAS - NS Group B	
[mm]	[mm]	[mm]	[kN]	[kN]	[kN]	[kN]	[kN]	[kN]	[kN]
14 × 50 *1.7	17.0	48.0	52	74	86 - 95	74 - 83	123 - 138	108 - 123	4.0
16 × 45 *5.8,9,12	19.2	54.4	68	96	113 - 125	97 - 109	161 - 181	141 - 161	5.7
16 × 56 *4.11	22.0	58.0	68	96	113 - 125	97 - 109	161 - 181	141 - 161	5.2
16 × 64 *6	20.0	55.0	68	96	113 - 125	97 - 109	161 - 181	141 - 161	5.1
16 × 80 *2.13	22.4	58.0	68	96	113 - 125	97 - 109	161 - 181	141 - 161	4.7
18 × 63 *4.11	24.0	65.0	86	122	143 - 158	122 - 137	204 - 229	178 - 204	6.5
18 × 64 *1.7	21.0	60.0	86	122	143 - 158	122 - 137	204 - 229	178 - 204	6.6
18 × 90 *2.13	25.0	64.0	86	122	143 - 158	122 - 137	204 - 229	178 - 204	6.0
19 × 64.5 *1.7	22.0	63.0	95	136	159 - 176	136 - 153	227 - 255	198 - 227	7.6
19 × 75 *6	22.0	63.0	95	136	159 - 176	136 - 153	227 - 255	198 - 227	7.1
20 × 56 *5.12	24.0	72.0	105	151	176 - 195	151 - 170	251 - 285	220 - 251	9.0
20 × 70 *4.11	27.0	72.0	105	151	176 - 195	151 - 170	251 - 285	220 - 251	8.2
22 × 86 *1.7	26.0	73.0	128	182	213 - 236	182 - 205	304 - 342	266 - 304	9.5
24 × 86 *1.7	28.0	79.0	152	217	253 - 280	217 - 244	362 - 407	317 - 362	11.6
24 × 87.5 *1.7	28.0	79.0	152	217	253 - 280	217 - 244	362 - 407	317 - 362	11.5
26 × 73 *5.12	31.2	94.0	178	255	297 - 329	255 - 287	425 - 448	372 - 425	15.0
26 × 91 *4.11	35.0	94.0	178	255	297 - 329	255 - 287	425 - 448	372 - 425	14.0
26 × 92 *1.7	30.0	86.0	178	255	297 - 329	255 - 287	425 - 448	372 - 425	13.7
26 × 100 *6	31.0	87.0	178	255	297 - 329	255 - 287	425 - 448	372 - 425	13.3
30 × 84 *5.12	36.0	108.0	238	339	396 - 438	339 - 382	565 - 636	495 - 565	20.0
30 × 105 *4.11	39.0	108.0	238	339	396 - 438	339 - 382	565 - 636	495 - 565	19.0
30 × 108 *1.7	34.0	98.0	238	339	396 - 438	339 - 382	565 - 636	495 - 565	18.0
30 × 120 *6	36.0	102.0	238	339	396 - 438	339 - 382	565 - 636	495 - 565	17.5
34 × 126 *1.7	38.0	110.0	305	436	508 - 563	436 - 490	726 - 817	636 - 726	22.7
34 × 136 *6	39.0	113.0	305	436	508 - 563	436 - 490	726 - 817	636 - 726	22.5
36 × 101 *5.12	43.2	130.0	342	489	570 - 631	489 - 550	814 - 916	713 - 814	29.0
38 × 126 *6	42.1	121.0	381	544	635 - 703	544 - 612	907 - 1 021	794 - 907	30.1

*1 - DIN 22252, 2 - DIN 762, 3 - DIN 763, 4 - DIN 764, 5 - DIN 766, 6 - FASING Technical Requirements, 7 - PN-G-46701, 8 - PN-G-46732, 9 - DIN 5684, 10 - PN-75/M-84543, 11 - PN-75/M-84541, 12 - PN-75/M-84540, 13 - DIN 20637.

Other sizes and parameters of case-hardened chains available following individual agreements with a customer.



Lifting chains, chains for hoists

The group of special, short-link chains with high hardness value and free of any production tension, of standard precision, applied in chain slings, used in lifting and carrying the loads.

⚠ Hot dip galvanizing of lifting chains grade 10, 11 and 12 is not allowed!

Short link lifting chains

Marking

FAS – FASING

MAX – characterized with high hardness and made of manganese-nickel-molybdenum-chromium alloy steel with micro additives in compliance with DIN 17115 standard and FASING Technical Requirements

10 – strength grade $\geq 1\ 000$ MPa

11 – strength grade $\geq 1\ 100$ MPa

12 – strength grade $\geq 1\ 200$ MPa

FAS MAX – FASING own marking

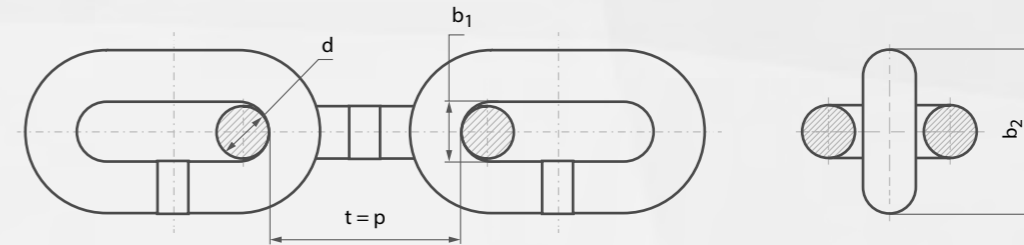

acc. to PAS 1061, ASTM A973/A973M
and FASING Technical Requirements
(grade 10, 11, 12)

Dimensions and mechanical properties

Chain size d × t (p)	t=p	b ₁ min.	b ₂ max.	Grade 10 • FAS MAX 10			Grade 11 • FAS MAX 11			Grade 12 • FAS MAX 12			~Weight [kg/m]
				Capacity [t]	Test force [kN]	Breaking force min. [kN]	Capacity [t]	Test force [kN]	Breaking force min. [kN]	Capacity [t]	Test force [kN]	Breaking force min. [kN]	
13×39	39 ± 1.2	16.9	48.1	6.7	166	265	7.5	182	291	8.0	199	318	4.1
16×48	48 ± 1.4	20.8	59.2	10.3	251	402	11.0	276	442	12.0	301	482	6.2
18×54	54 ± 1.6	23.4	66.6	12.5	318	509	14.0	340	560	15.5	381	610	8.0
19×57	57 ± 1.7	24.7	70.3	14.0	354	567	15.5	390	623	17.0	425	680	9.0
20×60	60 ± 1.8	26.0	74.0	16.0	393	628	17.5	432	690	19.0	471	754	9.9
22×66	66 ± 2.0	28.6	81.4	19.4	475	760	21.0	522	836	23.0	570	912	12.0
23×69	69 ± 2.1	29.9	85.1	20.0	519	831	22.8	571	914	24.9	623	997	13.1
24×72	72 ± 2.1	30.0	84.0	23.0	566	905	24.8	672	995	27.0	678	1085	14.5
25×75	75 ± 2.2	32.5	92.5	25.0	614	982	27.0	675	1080	29.4	736	1176	15.6
26×78	78 ± 2.3	33.8	96.2	26.5	664	1060	29.0	730	1168	31.8	796	1274	16.8
28×84	84 ± 2.5	36.4	104.0	30.5	769	1230	34.0	846	1354	37.0	923	1477	19.5
30×90	90 ± 2.7	37.5	105.0	35.5	884	1415	39.0	972	1554	42.5	1060	1696	22.1
32×96	96 ± 2.9	41.6	118.0	40.5	1006	1610	44.0	1105	1768	48.0	1206	1929	25.4
36×108	108 ± 3.2	46.8	133.0	50.0	1272	2035	56.0	1399	2238	61.0	1526	2442	32.1
38×114	114 ± 3.4	49.4	140.6	56.5	1420	2270	62.5	1559	2494	68.0	1700	2720	35.8
40×120	120 ± 4.0	52.0	148.0	62.5	1571	2515	69.0	1727	2763	75.5	1884	3014	39.7
45×135	135 ± 4.0	58.5	167.0	81.0	1988	3180	87.5	2186	3498	95.5	2384	3815	52.2
48×144	144 ± 4.3	62.4	177.6	92.0	2263	3620	99.5	2487	3980	108.5	2713	4341	57.2
50×150	150 ± 4.5	65.0	185.0	98.0	2453	3925	108.0	2698	4318	118.0	2944	4710	62.0

Total unit elongation
at breaking force
in a natural black state
gr. 10 - min. 25%,
gr. 11, 12 - min. 20%.

Working Load Limit and Working Force
(WLL, WF) should not exceed 25% of breaking force.

Fatigue testing
T = min. 20 000 cycles

acc. to PN - EN 818 - 2 (grade 8)

Dimensions and mechanical properties

Chain size d × t (p)	t = p	b ₁ min.	b ₂ max.	Capacity	Grade 8		
					Test force	Breaking force min.	~Weight
[mm]	[mm]	[mm]	[mm]	[t]	[kN]	[kN]	[kg/m]
13 × 39	39 ± 1.2	16.9	48.1	5.3	133	212	4.1
16 × 48	48 ± 1.4	20.8	59.2	8.0	201	322	6.2
18 × 54	54 ± 1.6	23.4	66.6	10.0	254	407	8.0
19 × 57	57 ± 1.7	24.7	70.3	11.2	284	454	9.0
20 × 60	60 ± 1.8	26.0	74.0	12.5	314	503	9.9
22 × 66	66 ± 2.0	28.6	81.4	15.0	380	608	12.0
23 × 69	69 ± 2.1	29.9	85.1	16.0	415	665	13.1
24 × 72	72 ± 2.1	30.0	84.0	18.0	452	723	14.5
25 × 75	75 ± 2.2	32.5	92.5	20.0	491	785	15.6
26 × 78	78 ± 2.3	33.8	96.2	21.2	531	850	16.8
28 × 84	84 ± 2.5	36.4	104.0	25.0	616	985	19.5
30 × 90	90 ± 2.7	37.5	105.0	28.0	706	1130	22.1
32 × 96	96 ± 2.9	41.6	118.0	31.5	804	1290	25.4
36 × 108	108 ± 3.2	46.8	133.0	40.0	1020	1630	32.1
38 × 114	114 ± 3.4	49.4	140.6	45.0	1130	1810	35.8
40 × 120	120 ± 4.0	52.0	148.0	50.0	1260	2010	39.7
45 × 135	135 ± 4.0	58.5	167.0	63.0	1590	2540	52.2
48 × 144	144 ± 4.3	62.4	177.6	72.0	1800	2890	57.2
50 × 150	150 ± 4.5	65.0	185.0	78.5	1963	3140	62.0

Total unit elongation at breaking force in a natural black state grade 8 - min. 20%.

Working Load Limit and Working Force (WLL, WF) should not exceed 25% of breaking force.

Fatigue testing
T = min. 20 000 cycles

Chain in grade 4 acc. to PN-EN 818-3 is available following the individual agreements with a customer.

Working Load Limit WLL [t]

Nominal size	Single-leg				Two-leg							
	factor 1.0				0° < 45° factor 1.4							
[mm]	gr. 8	gr. 10	gr. 11	gr. 12	gr. 8	gr. 10	gr. 11	gr. 12	gr. 8	gr. 10	gr. 11	gr. 12
13	5.3	6.5	7.5	8.0	7.5	9.1	10.5	11.2	5.3	6.5	7.5	8.0
16	8.0	10.3	11.0	12.0	11.2	14.4	15.4	16.8	8.0	10.3	11.0	12.0
18	10.0	12.5	14.0	15.5	14.0	17.5	19.6	21.7	10.0	12.5	14.0	15.5
19	11.2	14.0	15.5	17.0	16.0	19.6	21.7	23.8	11.2	14.0	15.5	17.0
20	12.5	16.0	17.5	19.0	17.0	22.4	24.5	26.6	12.5	16.0	17.5	19.0
22	15.0	19.4	21.0	23.0	21.2	27.1	29.4	32.2	15.0	19.4	21.0	23.0
26	21.2	26.5	29.0	31.8	30.0	37.1	40.6	44.5	21.2	26.5	29.0	31.8
28	25.0	30.5	34.0	37.0	33.5	42.7	47.6	51.8	25.0	30.5	34.0	37.0
30	28.0	35.5	39.0	42.5	39.2	49.7	54.6	59.5	28.0	35.5	39.0	42.5
32	31.5	40.0	44.0	48.0	45.0	56.0	61.6	67.2	31.5	40.0	44.0	48.0
36	40.0	50.0	56.0	61.0	56.0	70.0	61.6	85.4	40.0	50.0	56.0	61.0
38	45.0	56.5	62.5	68.0	63.0	78.4	78.4	95.2	45.0	56.5	62.5	68.0
40	50.0	62.5	69.0	75.5	70.0	87.5	96.6	105.7	50.0	62.5	69.0	75.5
45	63.0	81.0	87.5	95.5	88.2	113.4	122.5	133.7	63.0	81.0	87.5	95.5
50	78.5	98.0	108.0	118.0	109.9	137.2	151.2	165.2	78.5	98.0	108.0	118.0

Working Load limit WLL [t]

Nominal size	Three- and four-leg								Endless chain sling in choke hitch			
	0° < 45° factor 2.1				45° < 60° factor 1.5				factor 1.6			
[mm]	gr. 8	gr. 10	gr. 11	gr. 12	gr. 8	gr. 10	gr. 11	gr. 12	gr. 8	gr. 10	gr. 11	gr. 12
13	11.1	13.6	15.7	16.8	7.9	9.70	11.2	12.0	8.4	10.4	12.0	12.8
16	16.8	21.6	23.1	25.2	12.0	15.40	16.5	18.0	12.8	16.4	17.6	19.2
18	21.0	26.2	29.4	32.5	15.0	18.75	21.0	23.2	16.0	20.0	22.4	24.8
19	23.5	29.4	32.5	35.7	16.8	21.00	23.2	25.5	17.9	22.4	24.8	27.2
20	26.2	33.6	36.7	39.9	18.7	24.00	26.2	28.5	20.0	25.6	28.0	30.4
22	31.5	40.7	44.1	48.3	22.5	29.10	31.5	34.5	24.0	31.0	33.6	36.8
26	44.5	55.6	60.9	66.7	31.8	39.70	43.5	47.7	33.9	42.4	46.4	50.8
28	52.5	64.0	71.4	77.7	37.5	45.70	51.0	55.5	40.0	48.8	54.4	59.2
30	58.8	74.5	81.9	89.2	42.0	53.20	58.5	63.7	44.8	56.8	62.4	68.0
32	66.1	84.0	92.4	100.8	47.2	60.00	66.0	72.0	50.4	64.0	70.4	76.8
36	84.0	105.0	117.6	128.1	60.0	75.00	84.0	91.5	64.0	80.0	89.6	97.6
38	94.5	118.6	131.2	142.8	67.5	84.70	93.7	102.0	72.0	90.4	100.0	108.8
40	105.0	131.2	144.9	158.5	75.0	93.70	103.5	113.2	80.0	100.0	110.4	120.8
45	132.3	170.1	183.7	200.5	94.5	121.50	131.2	143.2	100.8	129.6	140.0	152.8
50	164.8	205.8	226.8	247.8	117.7	147.00	162.0	177.0	125.6	156.8	172.8	188.8



Changes of Working Load Limit in relation to temperature
Working Load Limit in % WLL

Temperature t [°C]			
-40 < t < 200	200 < t < 300	300 < t < 400	t > 400
100%	90%	75%	not allowed

Chains for hoists
acc. to PN-G-46732 and DIN 5684

Application
Manually and power operated chain hoists suited for mechanization of lifting and transportation services.

FASING is authorized to manufacture calibrated short link lifting chains on the basis of the Decision No. UD-09-78-E/2-07 issued by The Office of Technical Inspection.

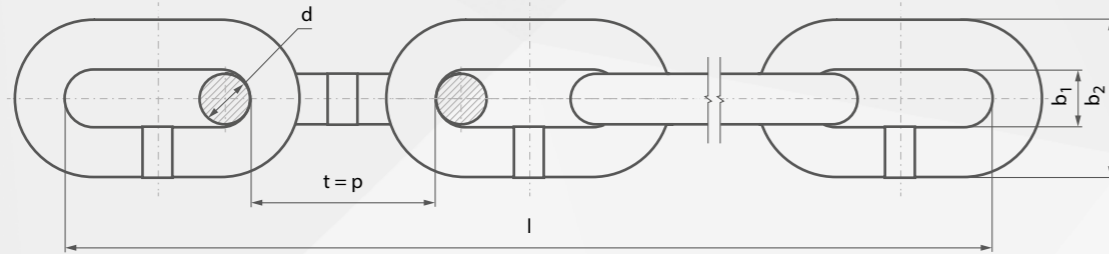

Dimensions

Chain size d × t (p)	d	t = p	b ₁ min.	b ₂ max.	l max.	~Weight
[mm]	[mm]	[mm]	[mm]	[mm]	[m]	[kg/m]
9 × 27	9 ± 0.4	27	10.8	30.4	50	1.8
11 × 31	11 ± 0.4	31	13.2	37.4	50	2.7
13 × 36	13 ± 0.5	36	15.6	44.2	50	3.8
16 × 45	16 ± 0.6	45	19.2	54.4	50	5.7

Mechanical properties

Chain size d × t (p) [mm]	Grade 3*		Grade 5		Grade 6		Grade 8	
	Test force [kN]	Breaking force min. [kN]	Test force [kN]	Breaking force min. [kN]	Test force [kN]	Breaking force min. [kN]	Test force [kN]	Breaking force min. [kN]
9 × 27	25	40	32	63	40	80	50	100
11 × 31	40	63	50	100	60	125	75	150
13 × 36	50	80	67	132	85	170	106	212
16 × 45	80	125	100	200	125	250	160	320

Total unit elongation at breaking force:
grade 3 – min. 25%, grade 5, 6, 8 – min. 10%

* shall not be used in power operated chain hoists

Hoisting chain parameters for the strands of 150 m in length

Chain size d × t (p) [mm]	9 × 27	9 × 27	11 × 31	11 × 31	11 × 31	13 × 36	13 × 36	13 × 36	16 × 45	16 × 45	16 × 45
Grade	5	6	5	6	8	5	6	8	5	6	8
Number of links	1-5555	1-5555	1-4839	1-4839	1-4839	1-4167	1-4167	1-4167	1-3333	1-3333	1-3333

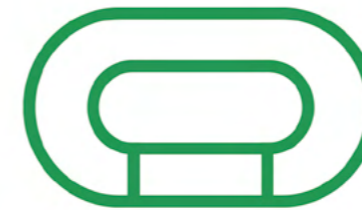

Chains for
marine
and **fishing**
industry,
general purpose
chains and
accessories

FASFISH
Chains for marine and fishing industry
acc. to FASING Technical Requirements

Mechanical properties

Type of chain	RTN/RTK Fishing Technical non-calibrated/calibrated				RTKO Fishing Technical calibrated, annealed				RSKO* Fishing Special calibrated, annealed						
	Grade	3	4	5	6	7	8	9	9,5	7	8	9	9,5	10	
Hardness min. [HBW]	-	300	300	300	350	350	360	360	390	440	350	350	380	410	440
Minimum stress at breaking force Rm [N/mm ²]		320	400	500	630	700	800	900	950		700	800	900	950	1000

* chain of special increased resistance to pit and stress corrosion

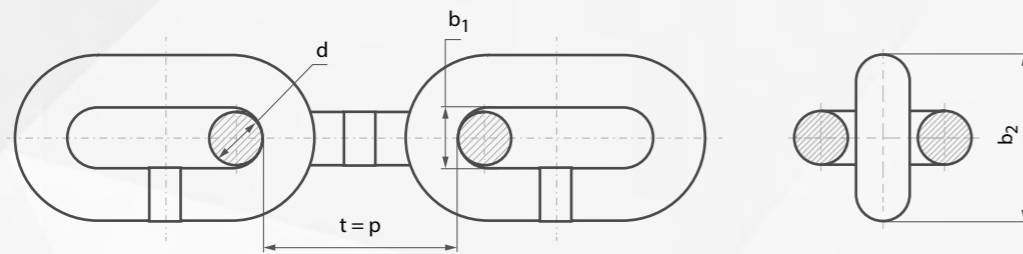

Short-link chains

Dimensions and mechanical properties

Chain size d × t (p) [mm]	b ₁ min. [mm]	Breaking force min. [kN] Grade				~Weight [kg/m]
		5	6	8	9,5	
16 × 48	22.4	201	253	322	382	5.7
19 × 57	27.0	284	357	454	539	8.1
20 × 60	27.0	314	396	503	597	9.0
22 × 66	28.6	380	479	608	722	10.9
26 × 78	32.5	531	669	849	1009	15.2

Medium-link chains

Dimensions and mechanical properties

Chain size d × t (p) [mm]	b ₁ min. [mm]	Breaking force min. [kN] Grade				~Weight [kg/m]
		5	6	8	9,5	
16 × 64	24.0	201	253	322	382	5.1
18 × 64	21.0	254	321	407	483	6.6
19 × 75	30.0	284	357	454	539	7.2
19 × 76	28.5	284	357	454	539	7.1
22 × 86	26.0	380	479	608	722	9.9
22 × 88	31.0	380	479	608	722	11.6
24 × 86	28.0	452	570	724	860	12.4
26 × 91	35.0	531	669	849	1009	14.4
26 × 92	30.0	531	669	849	1009	14.1
30 × 108	37.5	707	891	1131	1343	19.0

Long-link chains

Dimensions and mechanical properties

Chain size d × t (p) [mm]	b ₁ min. [mm]	Breaking force min. [kN] Grade				~Weight [kg/m]
		5	6	8	9,5	
16 × 100	26	201	253	322	382	4.3
19 × 100	27	284	357	503	597	6.5
22 × 120	36	380	479	608	722	8.9
26 × 140	41	531	669	849	1009	12.9

General purpose chains

calibrated, link type
grade 6, grade B acc. to PN-G-46701
and FASING Technical Requirements

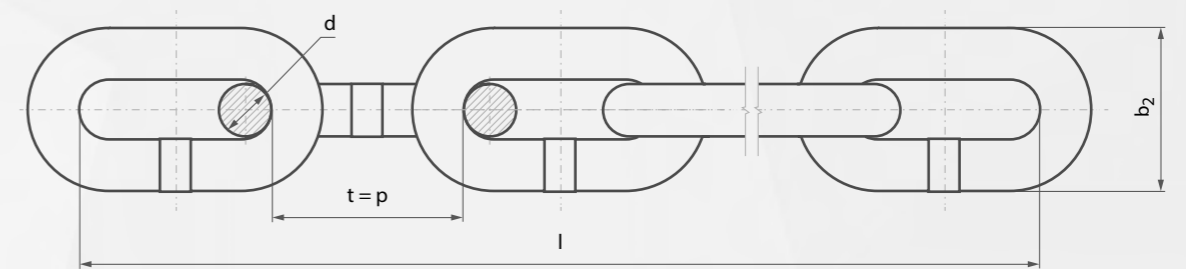

Dimensions and mechanical properties

Chain size d × t (p) [mm]	d [mm]	t=p [mm]	b ₂ max. [mm]	l max. [m]	Breaking force min. [kN]	~Weight [kg/m]
18 × 64	18 ± 0.5	64.0	60	150	320	6.6
19 × 64.5	19 ± 0.5	64.5	63	150	360	7.6
22 × 86	22 ± 0.7	86.0	73	150	490	9.5
24 × 86	24 ± 0.8	86.0	79	150	570	11.6
26 × 92	26 ± 0.8	92.0	85	150	670	13.7
30 × 108	30 ± 0.9	108.0	98	100	890	18.0
34 × 126	34 ± 1.0	126.0	109	100	1150	22.7
38 × 137	38 ± 1.1	137.0	121	100	1420	29.0
42 × 152	42 ± 1.3	152.0	133	100	1800	35.3

General-purpose chains

non-calibrated, heat treated

mechanical properties to be agreed with a customer

Dimensions

Chain size d × t (p) [mm]	d [mm]	t = p [mm]	b ₂ max. [mm]	l max. [m]	~Weight [kg/m]
14 × 47	14	47	51	150	4.0
18 × 60	18	60	64	150	6.6
19 × 60	19	60	67	150	7.6
22 × 82	22	82	77	150	9.5
24 × 82	24	82	83	150	11.6
26 × 87	26	87	90	150	13.7
30 × 102	30	102	103	100	18.0
34 × 121	34	121	115	100	22.7
38 × 132	38	132	126	100	29.0
42 × 140	42	140	144	100	35.3

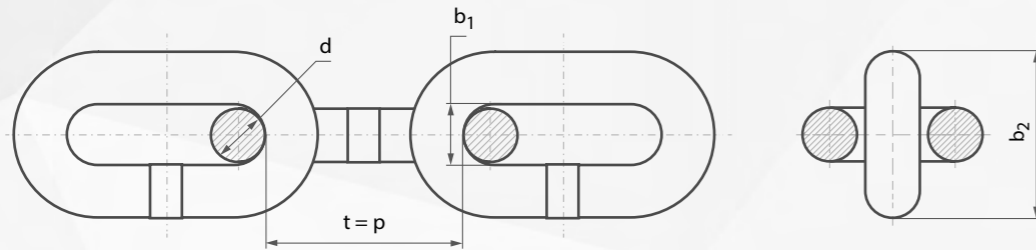
General purpose chains**acc. to DIN 762****Dimensions and mechanical properties**

Chain size d × t (p) [mm]	d [mm]	t = p [mm]	b ₁ min. [mm]	b ₂ max. [mm]	Grade 2			Grade 3			~Weight [kg/m]
					Capacity max. [t]	Test force [kN]	Breaking force min. [kN]	Capacity max. [t]	Test force [kN]	Breaking force min. [kN]	
13 × 65	13 ± 0.5	65	18.2	46.8	12.5	25	63	16	40	80	3.1
16 × 80	16 ± 0.6	80	22.4	57.6	20.0	40	100	25	63	125	4.7
18 × 90	18 ± 0.9	90	25.0	65.0	25.0	50	125	32	80	160	6.0
20 × 100	20 ± 1.0	100	28.0	72.0	32.0	63	160	40	100	200	7.4

Chains are also available in the following grades: 5, 6, 8 and 9.
Unit elongation at breaking min. 15%.**acc. to DIN 763, PN - 75/M - 84543****Dimensions and mechanical properties**

Chain size d × t (p) [mm]	d [mm]	t = p [mm]	b ₁ min. [mm]	b ₂ max. [mm]	Capacity max. [t]	Test force [kN]	Breaking force min. [kN]	~Weight [kg/m]
8 × 52	8 ± 0.4	52	14.4	33.6	0.40	10	25	1.10
10 × 65	10 ± 0.5	65	18.0	42.0	0.63	16	40	1.75
13 × 82	13 ± 0.65	82	23.4	54.6	1.00	25	63	3.10
16 × 100	16 ± 0.8	100	28.8	67.2	1.60	40	100	4.70

Chains are also available in the following grades: 5, 6, 8 and 9.
Unit elongation at breaking min. 20%.**General-purpose chains**

acc. to DIN 764

Dimensions and mechanical properties

Chain size d × t (p) [mm]	d [mm]	t = p [mm]	b ₁ min. [mm]	b ₂ max. [mm]	Grade 2			Grade 3			~Weight [kg/m]
					Capacity max. [t]	Test force [kN]	Breaking force min. [kN]	Capacity max. [t]	Test force [kN]	Breaking force min. [kN]	
13 × 45	13 ± 0.5	45	18	47	16	32	63	21.2	53	85	3.5
16 × 56	16 ± 0.6	56	22	58	25	50	100	32.0	80	125	5.2
18 × 63	18 ± 0.9	63	24	65	32	63	125	40.0	100	160	6.5
20 × 70	20 ± 1.0	70	27	72	40	80	160	50.0	125	200	8.2
23 × 80	23 ± 1.2	80	31	83	50	100	200	67.0	170	265	11.0
26 × 91	26 ± 1.3	91	35	94	63	125	250	85.0	212	340	14.0
28 × 98	28 ± 1.4	98	36	101	75	150	300	100.0	250	400	16.5
30 × 105	30 ± 1.5	105	39	108	85	170	340	112.0	280	450	19.0
33 × 115	33 ± 1.7	115	43	119	100	200	400	132.0	335	530	22.5
36 × 126	36 ± 1.8	126	47	130	125	250	500	160.0	400	630	26.5
39 × 136	39 ± 2.0	136	51	140	140	280	560	190.0	475	750	31.0

Chains are also available in the following grades: 5, 6, 8 and 9.
Unit elongation at breaking min. 20%.**acc. to DIN 766****Dimensions and mechanical properties**

Chain size d × t (p) [mm]	d [mm]	t = p [mm]	b ₁ min. [mm]	b ₂ max. [mm]	Capacity max. [t]	Grade 3		~Weight [kg/m]
						Test force [kN]	Breaking force min. [kN]	
11 × 31	11 ± 0.4	31	13.2	40	1.6	40	63	2.7
13 × 36	13 ± 0.5	36	15.6	47	2.0	50	80	3.9
14 × 41	14 ± 0.6	41	16.8	50	2.5	63	100	4.4
16 × 45	16 ± 0.6	45	19.2	58	3.2	80	125	5.8
18 × 50	18 ± 0.9	50	21.6	65	4.0	100	160	7.4
20 × 56	20 ± 1.0	56	24.0	72	5.0	125	200	9.0
23 × 64	23 ± 1.2	64	27.6	83	6.3	160	250	12.0
26 × 73	26 ± 1.3	73	31.2	94	8.0	200	320	15.0
28 × 78	28 ± 1.4	78	33.6	101	10.0	250	400	18.0
30 × 84	30 ± 1.5	84	36.0	108	11.2	280	450	20.0
32 × 90	32 ± 1.6	90	38.4	115	12.5	320	500	23.0
36 × 101	36 ± 1.8	101	43.2	130	16.0	400	630	29.0
40 × 112	40 ± 2.0	112	48.0	144	20.0	500	800	35.0
42 × 118	42 ± 2.1	118	50.0	151	22.4	560	900	40.0

Chains are also available in the following grades: 5, 6, 8 and 9.

Short-link general purpose chains
acc. to PN - 75/M - 84540

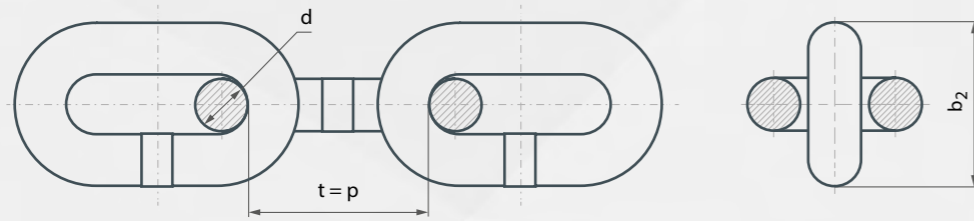

Dimensions and mechanical properties

Chain of N type				Chain of U type				~Weight [kg/m]
Chain size d x t (p) [mm]	b ₂ [mm]	Working load [t]	Test force [kN]	Breaking force min. [kN]	Working load [t]	Test force [kN]	Breaking force min. [kN]	
11 x 31	36	1.12	22.4	44.8	1.60	32.0	64.0	2.7
13 x 36	44	1.60	32.0	64.0	2.12	42.4	84.8	3.8
16 x 45	54	2.50	50.0	100.0	3.15	63.0	126.0	5.8
18 x 50	60	3.15	63.0	126.0	4.00	80.0	160.0	7.3
20 x 56	67	4.00	80.0	160.0	5.00	100.0	200.0	9.0
23 x 64	77	5.00	100.0	200.0	6.70	134.0	268.0	12.0
26 x 73	87	6.30	126.0	252.0	8.50	170.0	340.0	15.0
28 x 78	94	7.50	150.0	300.0	10.00	200.0	400.0	17.5
30 x 84	101	8.50	170.0	340.0	11.20	224.0	448.0	20.0
33 x 92	112	10.00	200.0	400.0	13.20	264.0	528.0	24.5
36 x 101	122	12.50	250.0	500.0	15.00	300.0	600.0	29.0
39 x 109	132	14.00	280.0	560.0	18.00	360.0	720.0	34.0
42 x 118	142	17.00	340.0	680.0	20.00	400.0	800.0	40.0

Chain of N type – strength min. 240 MPa (grade 2). Chain of U type – strength min. 300 MPa (grade 3).
Chains are also available in the following grades: 5, 6, 8 and 9.

Chains for suspension and transportation
acc. to DIN 20637

Application

For suspended railways, working units and additional equipment.

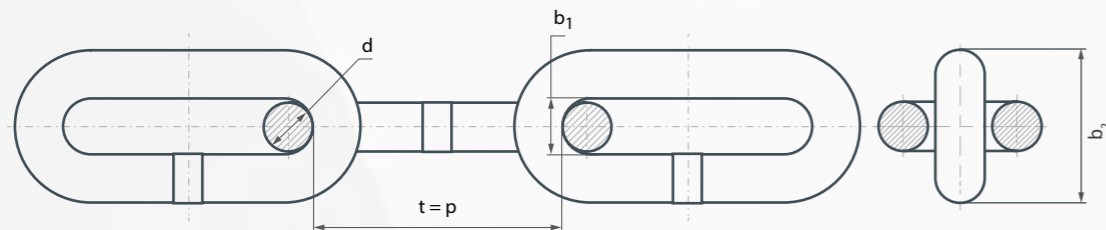

Dimensions and mechanical properties

Chain size d x t (p) [mm]	d [mm]	t [mm]	b ₁ [mm]	Test force [kN]	Breaking force min. [kN]	Elongation at		Bend test deflection min. [mm]	~ Weight [kg/m]
						test force max. [%]	breaking force min. [%]		
16 x 80	16 ± 0.6	80 ± 1.5	22.4 + 3/-0	60	180	1.6	20	21	4.7
18 x 90	18 ± 0.9	90 ± 1.5	25.0 + 3/-0	100	250	1.6	20	23	6.0

Accessories for general purpose chains

Rope Connecting Link

18 x 60.5 mm

Application

Used for connecting the rope in suspended rail SKL-5000 H.

Parameters

Minimum breaking force – 180 kN

Weight – 0.46 kg

Catalog number – 718 00 000

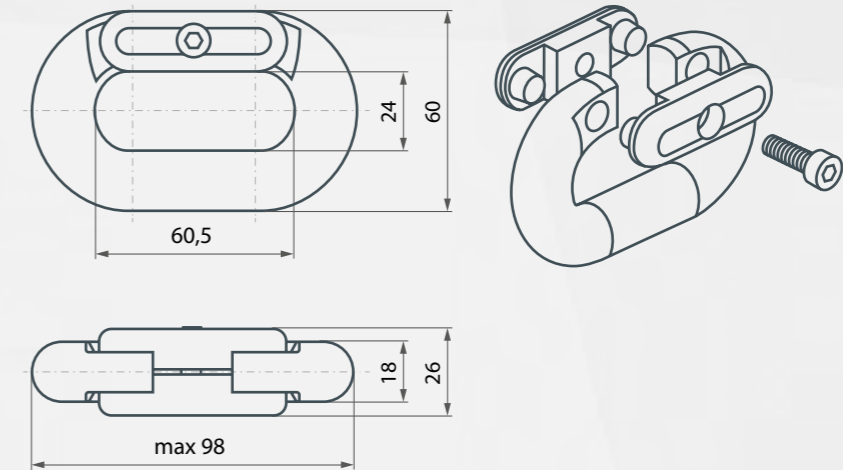

C and S-type hooks

The hooks may only be used to attach ties that are subject to static, unidirectional forces, acting along the axis. They are designed for attaching or transporting any kind of equipment according to the user's selection and decision or according to an individual design of the manufacturer, the seller - FASING Plc. to the order of the buyer, user. The hooks are used in every market sector, wherever it is necessary to suspend or connect any statically loaded elements. The hooks are used in the mining industry, where they are used to suspend pipelines, electric cables, as well as in the fishing industry, timber industry, construction and many other economy branches. The hooks cannot be used for suspension in lifting devices.

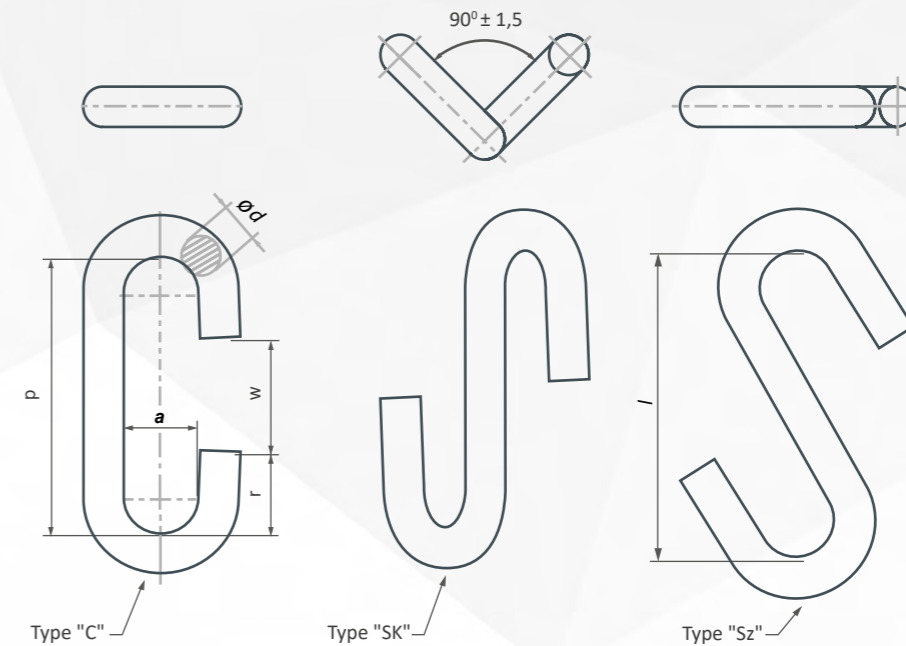

Dimensions of the hooks type "C" and "S"

Hooks							~ Weight
	d [mm]	p [mm]	l [mm]	a [mm]	r [mm]	w [mm]	[kg/pc.]
Ø 11/72	11 ^{+1.0} _{-0.2}	72 ^{±4}	90.5 ^{±5}	20.0 ⁺⁴	23 ^{±1}	25 ^{±1}	0.14
Ø 13/80	13 ^{+1.0} _{-0.2}	80 ^{±5}	95.0 ^{±6}	21.0 ⁺⁴	26 ^{±2}	28 ^{±2}	0.23
Ø 14/50	14 ^{+0.6} _{-0.2}	50 ^{±4}	68.0 ^{±6}	17.0 ⁺⁴	16 ^{±1}	18 ^{±1}	0.18
Ø 16/80	16 ^{+1.0} _{-0.2}	80 ^{±5}	100.0 ^{±6}	22.5 ⁺⁵	26 ^{±2}	28 ^{±2}	0.33
Ø 18/54	18 ^{+1.5} _{-0.2}	54 ^{±4}	72.5 ^{±6}	23.5 ⁺⁵	17 ^{±1}	20 ^{±1}	0.35
Ø 18/64	18 ^{+1.5} _{-0.2}	64 ^{±4}	81.5 ^{±6}	21.0 ⁺⁵	19 ^{±2}	26 ^{±2}	0.37
Ø 20/60	20 ^{+1.0} _{-0.3}	60 ^{±4}	-	26.0 ⁺⁶	19 ^{±1}	22 ^{±1}	0.48
Ø 22/66	22 ^{+1.1} _{-0.3}	66 ^{±4}	-	28.5 ⁺⁷	21 ^{±1}	24 ^{±1}	0.65
Ø 22/86	22 ^{+1.1} _{-0.3}	86 ^{±5}	-	25.0 ⁺⁵	28 ^{±2}	30 ^{±2}	0.73
Ø 24/86	24 ^{+1.0} _{-0.3}	86 ^{±5}	-	28.0 ⁺⁵	27 ^{±2}	32 ^{±2}	0.88
Ø 26/78	26 ^{+1.3} _{-0.3}	78 ^{±5}	-	34.0 ⁺⁸	25 ^{±1}	28 ^{±1}	1.08
Ø 26/92	26 ^{+1.3} _{-0.3}	92 ^{±5}	-	30.0 ⁺⁶	28 ^{±2}	36 ^{±2}	1.11
Ø 30/108	30 ^{+1.1} _{-0.3}	108 ^{±6}	-	34.0 ⁺⁶	34 ^{±2}	40 ^{±2}	1.70
Ø 32/96	32 ^{+1.6} _{-0.5}	96 ^{±6}	-	41.5 ⁺¹⁰	31 ^{±1}	34 ^{±1}	2.00
Ø 34/126	34 ^{+1.2} _{-0.5}	126 ^{±6}	-	38.0 ⁺⁶	41 ^{±3}	44 ^{±3}	2.50
Ø 38/137	38 ^{+1.3} _{-0.5}	136 ^{±6}	-	42.0 ⁺⁷	43 ^{±3}	49 ^{±3}	3.50
Ø 42/146	42 ^{+1.5} _{-0.5}	146 ^{±10}	-	46.0 ⁺¹⁰	45 ^{±4}	56 ^{±4}	4.70

Mechanical properties of the hooks type "C" and "S"

Hooks	Minimum static load deforming the hooks [t]			Permissible working load WLL [t]		
	Type "C"	Type "SK"	Type "Sz"	Type "C"	Type "SK"	Type "Sz"
Ø 11/72	2.4	2.0	2.7	1.2	1.0	1.0
Ø 13/80	3.0	-	-	1.5	-	-
Ø 14/50	3.8	-	-	1.9	-	-
Ø 16/80	5.2	4.0	3.2	2.6	2.0	1.6
Ø 18/54	6.6	5.8	4.4	3.3	2.9	2.2
Ø 18/64	6.6	5.8	4.4	3.3	2.9	2.2
Ø 20/60	8.0	-	-	4.0	-	-
Ø 22/66	9.4	-	-	4.7	-	-
Ø 22/86	9.4	-	-	4.7	-	-
Ø 24/86	10.0	-	-	5.0	-	-
Ø 26/78	10.8	-	-	5.4	-	-
Ø 26/92	10.8	-	-	5.4	-	-
Ø 30/108	18.0	-	-	9.0	-	-
Ø 32/96	21.0	-	-	9.5	-	-
Ø 34/126	3.0	-	-	10.5	-	-
Ø 38/137	27.0	-	-	13.5	-	-
Ø 42/146	38.0	-	-	19.0	-	-



Basic concepts

Terms, definitions and parameters

Geometry of links

The basic term which describes chain is the so-called "chain size" $d \times t$ or $d \times p$. This value is defined as the product of nominal diameter of the bar which link is made of – (d) and the highest internal link dimension value (t) or (p) – called link or chain pitch.

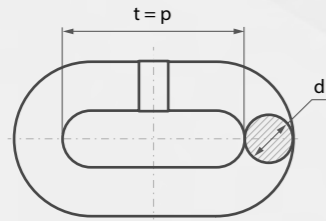

Link dimensions are always given in millimeters. For example: chain size 34x126 means that the nominal diameter (d) of the bar which link is made of is 34 mm, whereas, pitch (t) is 126 mm.

Link length

is defined as t / d ratio. The higher value of the ratio, the longer are the links.

Short-link chain ratio is $t / d \leq 3.0$

Medium-link chain ratio is $3.0 < t / d < 4.0$

Long-link chain ratio is $t / d \geq 4.0$

Chains that are used in flight bar conveyor drives are of ratio $t / d < 3.8$. This results from the kinematics of cooperation between links and chain seating in the sprocket.

Internal width (b₁)

is included in the standards. The value is always provided in its minimum clear width, measured next to the weld, below which the smooth cooperation between the curved link crowns is jeopardized. Internal width is defined as:

$$b_1 = d + \Delta S \text{ where } \Delta S \approx (0.1 \div 0.15) d$$

External width (b₂)

is included in the standards. The value is always provided as the maximum measurement. The minimum theoretical external width of the links made of round bars is defined as:

$$b_2 = 3d + \Delta S \text{ where } \Delta S \approx (0.1 \div 0.15) d$$

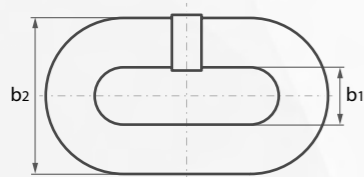

In many cases, the width value is too big. So, as not to compromise the rule of minimum internal width that guarantees the smooth cooperation between link crowns, and for design reasons, the flattened or forged links are used. Their width of flattening in link's straight sections is smaller than the minimum internal width value, as in the case of flat link chains.

Mechanical properties of chains

Testing and marking

Breaking force

is the maximum force that a sample withstands during the course of a static tensile test. The value is determined by cross-sectional area of the link, steel grade and type of heat treatment applied to the chain during the production process. The breaking force value, which is provided by the standards, is the minimum value that a steel link chain must endure during the tensile test.

Tensile stress

$$\sigma_z = \frac{P}{2F}$$

In order to compare static properties of all chains, the breaking force value has been defined in the following equation:

where:

σ_z – tensile stress [MPa]

P – breaking force of the chain [kN] – in accordance with the standard

F – cross-sectional area of the bar [m²]

If one takes the chain of fixed geometry, then through the change in steel grade and by applying various material heat treatment, one may acquire the tensile stress value of very wide range:

from $\sigma_z \approx 250$ MPa – for standard steel grades

up to $\sigma_z \approx 1000$ MPa – for alloy steel grades, heat-treated, including zonal heat-treated steels

Most common quality grades according to FASING

A wide range of strength properties has been divided into several subranges called quality grades. Various standards and technical requirements provide different ways of marking for quality grades. The below table presents the most common quality grades acc. to FASING.

Quality grades			Tensile stress min. [MPa]
Mining chains acc. to FASING	Mining chains acc. to PN, ISO, DIN and GB/T	General purpose chains, chains for fishing industry and special purpose chains	
		3.0	320
		4.0	400
		5.0	500
B	B	6.0	630
		7.0	700
C/DIN	C/DIN	8.0	800
C-PLUS		8.5	850
C-SUPER, PW-9		9.0	900
		9.5	950
D, D-3	D	10.0	1000
D-3 EXTRA		10.5	1050
E-FASING		11.0	1100

Chain elongation

If the breaking force value is exceeded, the chain breaks. Prior to this, the chain undergoes multiple deformations i.e. it elongates (except case-hardened chains, which deform slightly). The relationship between the force and elongation value is best presented in the so-called "elongation diagram", which is printed by a tensile testing machine in time of static tension testing.

Chain elongation diagram

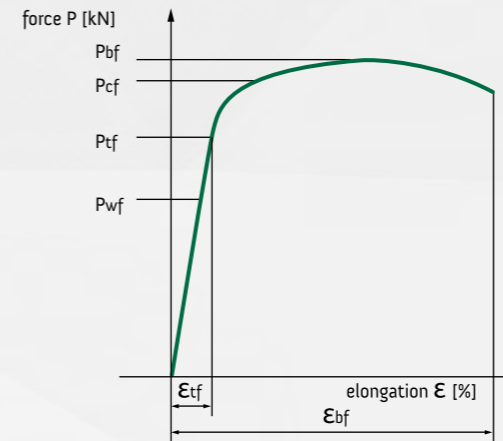

Pbf – breaking force

Pcf – calibration force (100% of chains are subject to calibration force)

Ptf – test force

Pwf – working force according to DIN 22252, DIN 22255 for mining chains

tf – elongation at test force [%]

bf – elongation at breaking force [%]

– elongation [%]

The chain elongation process may be divided into two stages:

Stage I – elongation is proportional to the applied force

Stage II – elongation increases rapidly and not in proportion to the applied force

The boundary value between those two stages is "test force", which somewhat simplified, constitutes the elastic limit of chains. If the elastic limit is exceeded, the chain undergoes plastic (permanent) deformation, i.e. the pitch increases as a result of overloading. Elongation at the test force should be kept to a minimum. The standards define the maximum value of elongation, so the chain is not subject to big elastic deformations. Usually, it does not exceed 2% of chain length; it depends on geometry and heat treatment.

Breaking force value Pbf is higher than calibration force by ca. 27%, higher than test force by ca. 33%, and higher than working force by ca. 60%.

$$Pbf \approx 1.27 Pcf \approx 1.33 Ptf \approx 1.6 Pwf$$

or,

$$Pwf \approx 0.83 Ptf \approx 0.79 Pcf \approx 0.625 Pbf$$

Maximum working force value that is recommended by FASING should not exceed 50% of breaking force i.e.:

$$Pwf = 0.5 Pbf$$

Elongation at breaking force

Elongation at breaking force should be at its highest value as the fracture energy or force needed to break the chain is related to the elongation. The higher value of energy needed for fracture, the more resistant is the chain to any overloading.

The actual value of elongation at breaking force should always be higher than the minimum value provided by the standards. In practice, its value should be higher than 10% of chain length.

Dynamic testing

Chains that are used in sprockets are additionally put under dynamic testing i.e. fatigue tests (pulsation). The pulsating load is periodically applied to chain sample within the maximum and minimum level of strain values provided by the standards. The criterion for fatigue test is identified as the minimum durability, presented in number of cycles, that shall be achieved per sample and comply with the following standards: PN-G-46701, DIN 22252 and DIN 22255.

! Any preservative coating that protects the chain surface (oil, lubricant, paint, zinc coating) results in a decrease of static and dynamic strength properties, as the cause of Rebinder Effect presence. The decrease of strength parameters exists in time of laboratory testing and during the first stage of chain maintenance.

Material testing

In this context, material testing should not mean chemical analysis or metallographic examination. Material testing concerns the properties of ready-to-use chains and the technology of weld manufacture. The testing includes a technological bending test on single chain links. During this test, the links are bent at a certain value called bend deflection f [mm] and shall not reveal any cracks or other visible defects in material or weld. Most standards provide bend deflection value as $f = d$ where: f – means bend deflection, d – means the diameter of the bar, which link is made of.

The next material test is the Charpy V-notch (impact energy KV) that is carried out according to the requirements provided in the standards. Charpy V-notch test is to study the link material resistance to brittle fracture.

Chain marking

depends on the standard and/or customer individual requirements under which the chain is made. All chains made by FASING have permanent marking (designation is stamped) in compliance with Instructions for Hammer Marking. Chain marking includes the manufacturer's marking, the grade, the month and the year of manufacture.



Capital Group FASING Plc.

11 Modelarska Street
40 - 142 Katowice

phone +48 32 735 00 00
fax +48 32 730 22 60

fasing@fasing.com.pl

